

# Wireless World

**Editor:**

H. W. BARNARD

**Technical Editor:**

T. E. IVALL, M.I.E.R.E.

**Deputy Editor:**

B. S. CRANK

**Assistant Editors:**
J. GREENBANK, B.A.  
G. B. SHORTER, B.Sc.
**Drawing Office:**

L. DARRAH

**Production:**

D. R. BRAY

**Advertisements:**
G. BENTON ROWELL (*Manager*)  
G. J. STICHBURY  
A. PETERS (*Classified Advertisements*)  
Telephone: 01-928 3333 Ext. 533

## Exhibitions — general or specialized

During the past 20 years or so, there has been a growing tendency for exhibitions, both in this country and abroad, to get bigger and bigger and more and more diverse in content. Instead of the Components Exhibition, for example, being concerned with components as it was originally in the days of the Grosvenor House show (of happy memory) it has grown into another all-embracing exhibition of components, instruments, electronics and automation. Shows of such size and diversity have, of course, a very useful function in that they provide the would-be buyer with a shop window stretching right across the industry. Many exhibitors and visitors, however, feel that they have become so diverse that they lack the impact of the more specialized exhibition. As an exhibition gains in popularity and grows in stature it almost inevitably attracts exhibitors with peripheral interests and in a few years it has very largely lost its identity as a specialized show. The progress of fragmentation then starts all over again and, as will have been noticed from our news pages and the list of exhibitions we publish each month, there has recently been a swing from generalization to specialization. A note in 'News of the Month' (p.172) gives details of the semiconductor exhibition — SEMINEX — to be held this month in a London hotel. It will be recalled that most, if not all, the semiconductor manufacturers withheld their support from last year's Components Exhibition and are not in the advanced list of exhibitors at this year's I.E.A. show. Other recent or forthcoming specialized exhibitions in the U.K. cover electro-optics, electronic packaging, audio, public address, communications etc. This may well be the future trend in exhibitions, brought about mainly for two reasons. First, the cost of exhibiting at a comparatively small specialized exhibition can be minimal because stands are limited in size and are not elaborate. Secondly, the specialized exhibition can be, and frequently is, linked with a conference, seminar or what have you, including papers dealing with a very limited field of interest.

Having said this about small specialized exhibitions we regret to find that the Physics Exhibition, which has had a character all its own for so many years, is possibly taking the reverse step. The regret is not so much in that it is joining forces with another show — the Labex (laboratory equipment) at Earls Court — but that the particular identity of this non-commercial, research-centred, exhibition may be lost.

It is interesting to note that contrary to the move to specialized exhibitions in this country the well-established gargantuan exhibitions on the Continent continue to grow in size and in popularity.

Despite *Wireless World's* diverse interests we prefer specialized exhibitions; they provide a better opportunity for a 'state of the art' report rather than the 'all things to all men' type of report, which ranges from microcircuits and discrete components through instruments and control equipment to complete systems.

We may be accused of being biased towards small specialized exhibitions because it makes our job of reporting easier. It is not so much the ease with which we can cover an exhibition — even one like SONEX with 60 or 70 exhibitors can take many man hours to cover factually — but we believe our readers prefer a true assessment of a particular field rather than a wide-ranging, disjointed catalogue of exhibits.

# Hand-portable Transceiver

## A design for 144-6MHz with battery-saving and squelch facilities

by *D. A. Tong, B.Sc., Ph.D. (G8ENN)*

Rather than build fixed station equipment, which could on occasion be taken outside, it was the author's intention to build portable equipment, which would also be suitable for fixed station use. A general view of the two-metre transceiver to be described is shown with its mains power supply and charging unit. Including batteries, loudspeaker and telescopic aerial, the overall size of the unit is 15 × 11 × 6cm and it weighs about 1kg. A highly sensitive receiver is included and the transmitter radiates an a.m. signal of about 1.5W carrier power. In order to go 'on the air', all one has to do is pull out the whip aerial and switch on.

Front panel space is at a high premium in miniature equipment, so wherever possible non-critical circuitry has been used, so that operator adjustment is not required. In order to obtain a reasonable period of operation between battery recharges, some limitation on power output must obviously be accepted. The batteries used by the author are rated at 900mAh and are able to provide a good day's operating at normal transmit-receive ratios. To conserve power, a front panel switch is fitted, which reduces the output

power from 1.5W to 400mW, which is ample for most local contacts. Long periods of monitoring a particular unoccupied receiving channel are also catered for by the inclusion of a sampling device in the receiver, which reduces the battery drain by a factor of ten. The ideal of 'instant operating' can be met only if care is taken in construction. Poor soldered joints and unanchored components can play havoc with reliability, but care is also essential in the design of the outer case.

### General circuit design

An overall block diagram of the transceiver is shown in Fig. 1. In the receive mode the unit functions as a dual-conversion superheterodyne in which most of the functions in the so-called 'tunable i.f.' are located in the Mullard i.c. type TAD100. The first intermediate frequency covers 10.7 to 12.7MHz with a first local oscillator on 133.333MHz. The second intermediate frequency is 470MHz. While not ideal, these frequencies were chosen for the following reasons: (a) a miniature block filter is available from Mullard Ltd at a

reasonable price (type LP1175 at 65p); (b) the tunable i.f. needs to be high enough for good first image rejection, but low enough to give good second image rejection and adequate v.f.o. stability.

In the crucial first stages of the receiver a cascode f.e.t. r.f. stage is followed by a f.e.t. mixer. This arrangement gives an excellent weak signal performance and is also relatively free from cross-modulation. The TAD100 includes driver transistors for a complementary pair of audio output transistors. Using the devices specified by Mullard (AC187 and AC188), up to three watts of audio power are available, and the receiver audio stages are therefore also used as a modulator in the transmit mode. Selection of either loudspeaker or modulation transformer as load is accomplished using a transistor gate circuit'. Audio input switching is carried out by a f.e.t. gate which also functions as a squelch gate, as indeed does the loudspeaker gate.

It is not necessary to interrupt any high current path during send-receive switching and this enables small-signal transistors to be used as combined switches and voltage stabilizers, to route stabilized supply voltages to the appropriate, low-level stages in the transceiver. In conjunction with a diode aerial switch, which is r.f. energized, these features reduce the send-receive switch to a single contact closure in the hand-microphone, and no relays are necessary.

In order to be able to operate in the stand-by mode for long periods without draining the battery, the inclusion of squelch (muting in the absence of a received signal) is doubly necessary, since the battery saver circuit requires some definite indication that a signal has been received during its periodic sampling of the monitored channel. When such a signal is received two things happen. First the muting of the receiver is lifted and secondly the sampling ceases and the receiver is continuously energized. Sampling resumes only after a delay of about thirty seconds after the received signal disappears. The sampling process is inhibited if an external power source is used, since it is then unnecessary.

The transmitter is relatively straightforward and uses a crystal controlled oscillator at half the output frequency. Modulation is applied to the driver and



*The transceiver and its main power unit and battery charger.*

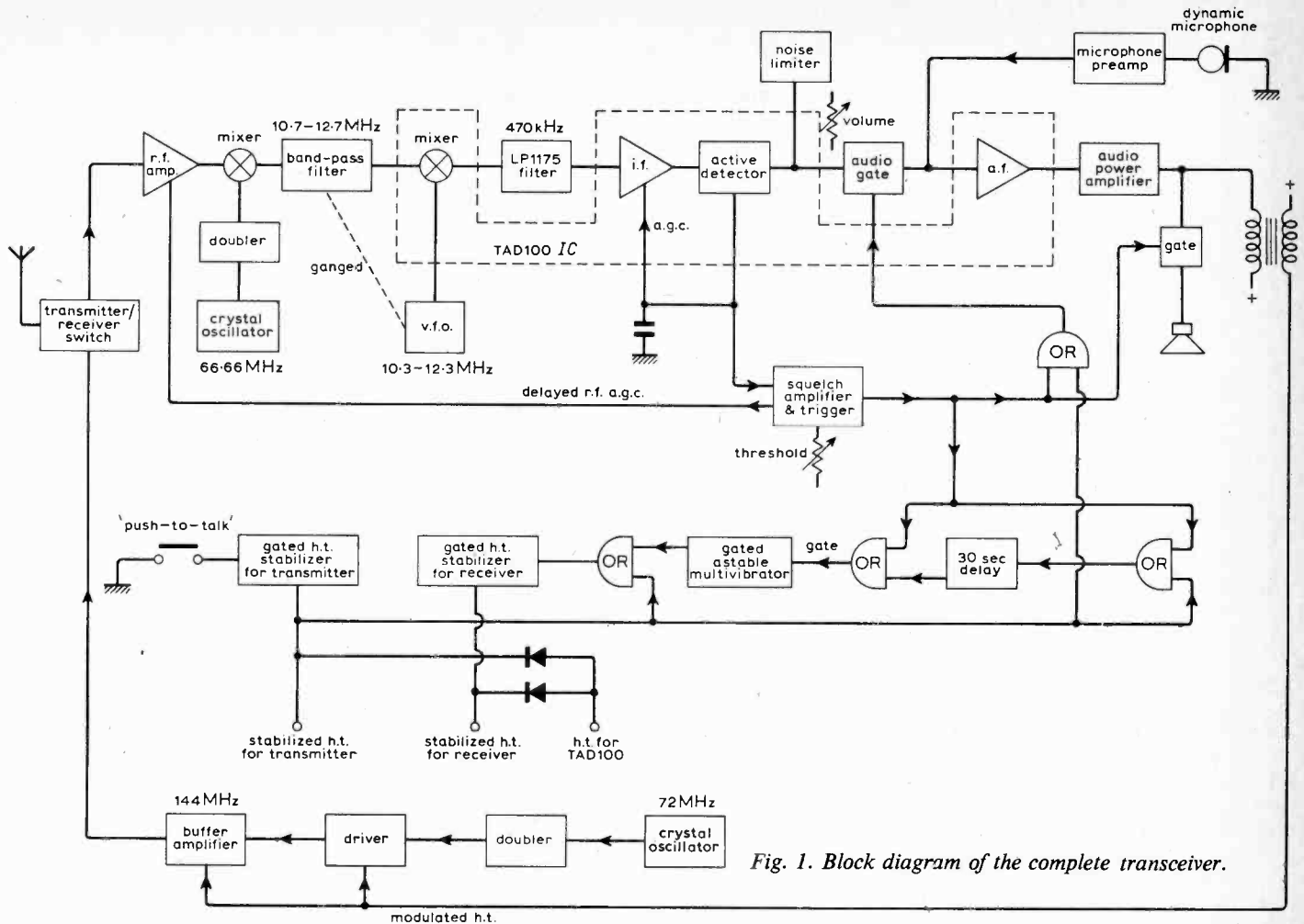

Fig. 1. Block diagram of the complete transceiver.

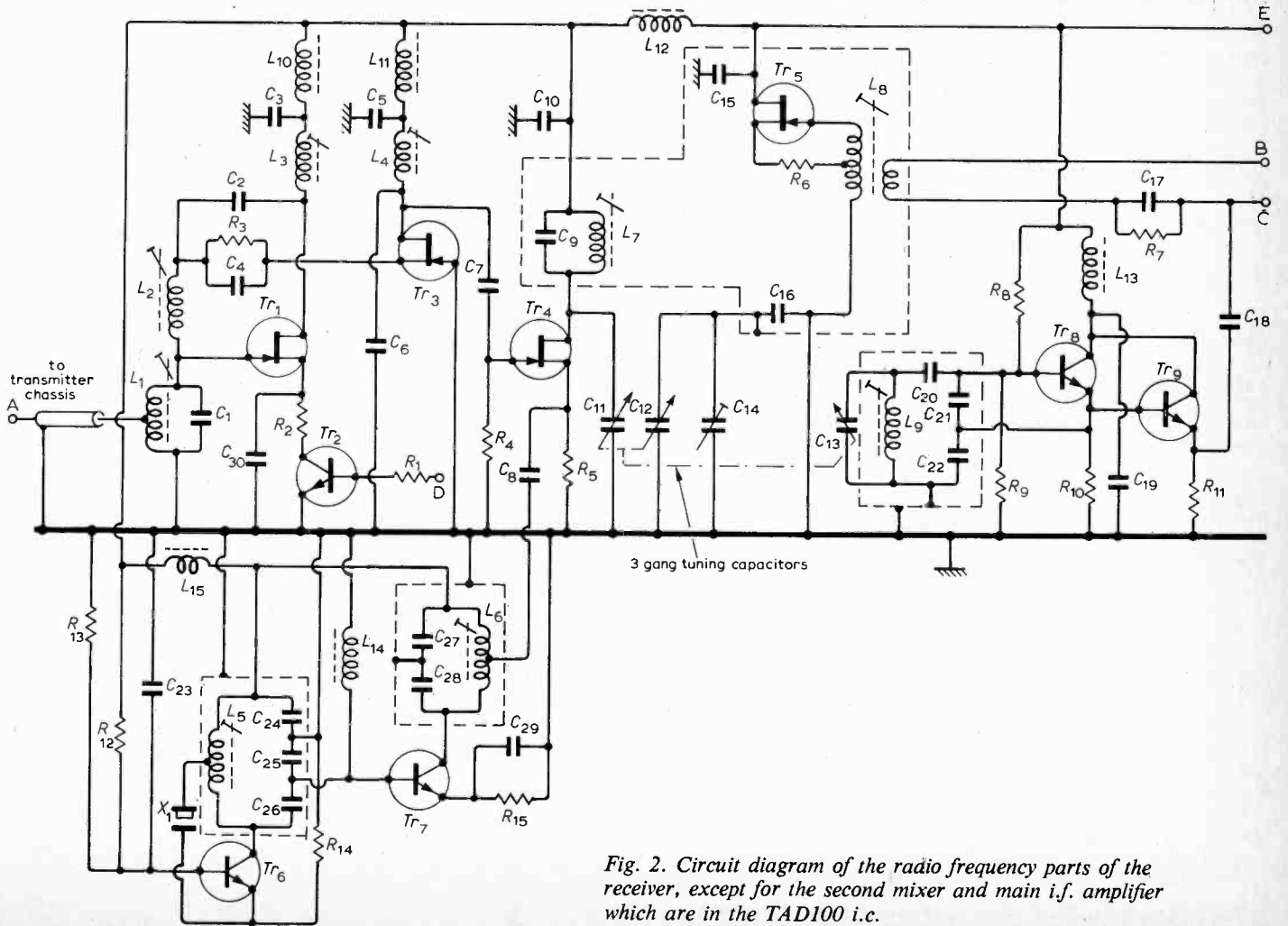

Fig. 2. Circuit diagram of the radio frequency parts of the receiver, except for the second mixer and main i.f. amplifier which are in the TAD100 i.c.

output stages and the receiver audio section is used as the modulator. The power output switch controls the amount of drive supplied by the second stage to the driver stage.

**The receiver**

The complete circuit diagram of the receiver is given in Figs. 2, 3 and 4, but this also includes most of the send-receive switching components. The cascode r.f. stage ( $Tr_1, Tr_3$ ) is straightforward to set up and the neutralizing adjustment ( $L_2$ ) is non-critical. The two transistors are not operated in series with respect to the power supply, because the latter should be larger than the sum of the two pinch-off voltages which could be up to 12V. The basic circuit has previously been used by D. J. Taylor<sup>2</sup>. In the present receiver however the a.g.c. arrangement is a little unconventional and uses a separate transistor,  $Tr_2$ , as a variable source resistance for  $Tr_1$ . At point *D* a positive

voltage decreasing with signal strength is required and this is obtained from the squelch amplifier ( $Tr_{19}$ , Fig. 4). The first mixer,  $Tr_4$ , is a conventional f.e.t. mixer with source injection from a frequency doubler,  $Tr_7$ , which is in turn driven by a crystal-controlled overtone oscillator,  $Tr_6$ , at 66.666MHz.

In dual-conversion receivers of this type, the most serious spurious response is at the second image frequency, that is, the frequency spaced by twice the last i.f. (470kHz) from the second local oscillator (10.235 to 12.235MHz). It is particularly serious, because it falls within the two-metre band itself and there is the likelihood therefore of strong signals being in its vicinity. The only cure, given a final i.f. of 470kHz, is to have good selectivity at the first i.f. In this receiver two loosely coupled tuned circuits at this frequency ( $L_7, L_8$ ) are ganged with the second local oscillator. The coupling is inductive; the two coils being spaced about 13mm

apart inside a double i.f. transformer can. The basic coupling can then be adjusted by fitting a single-turn loop around both coils and phased so as either to aid or oppose the existing coupling. A large increase in selectivity at the first i.f. was obtained in this receiver by adding a *Q*-multiplier ( $Tr_3$ ) to the second tuned circuit ( $L_8$ ). The *Q*-multiplication varies inversely with the value of  $R_6$  and the amount used is determined in practice by the accuracy of tracking of this tuned circuit with the v.f.o.

The frequency stability of an a.m. receiver should be such that the total drift under all conditions is small compared with the receiver bandwidth and this is achieved here with the v.f.o. circuit shown ( $Tr_8, Tr_9$ ). It is basically a Seiler oscillator<sup>3</sup> and  $Tr_9$  is used as a buffer stage.

The second mixer is located in the TAD100 i.c. and its output emerges from pin 14 to the input of the block filter at

Fig. 3. Circuit diagram of the part of the receiver which is built around the TAD100 i.c. The squelch and loud-speaker gates are also shown.

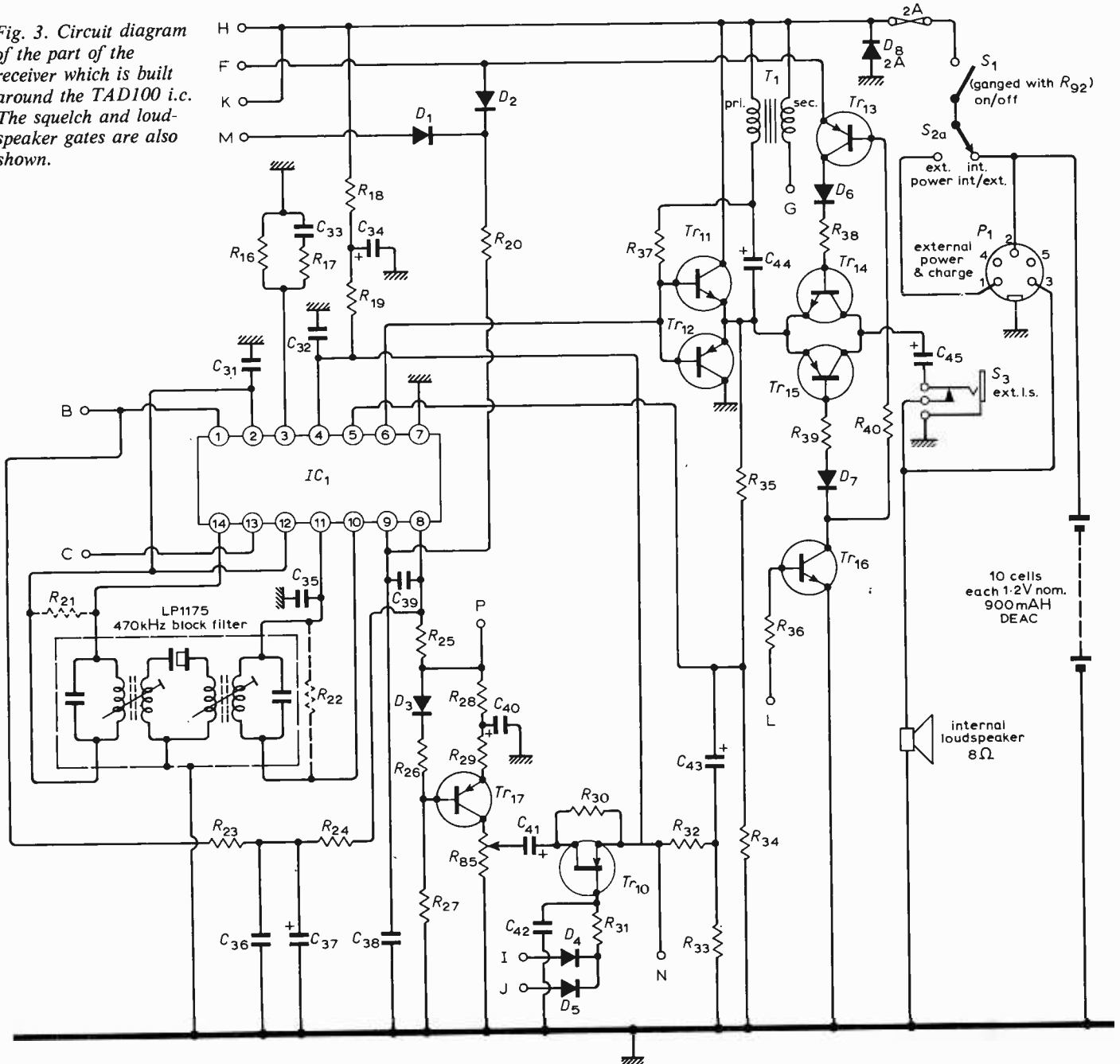
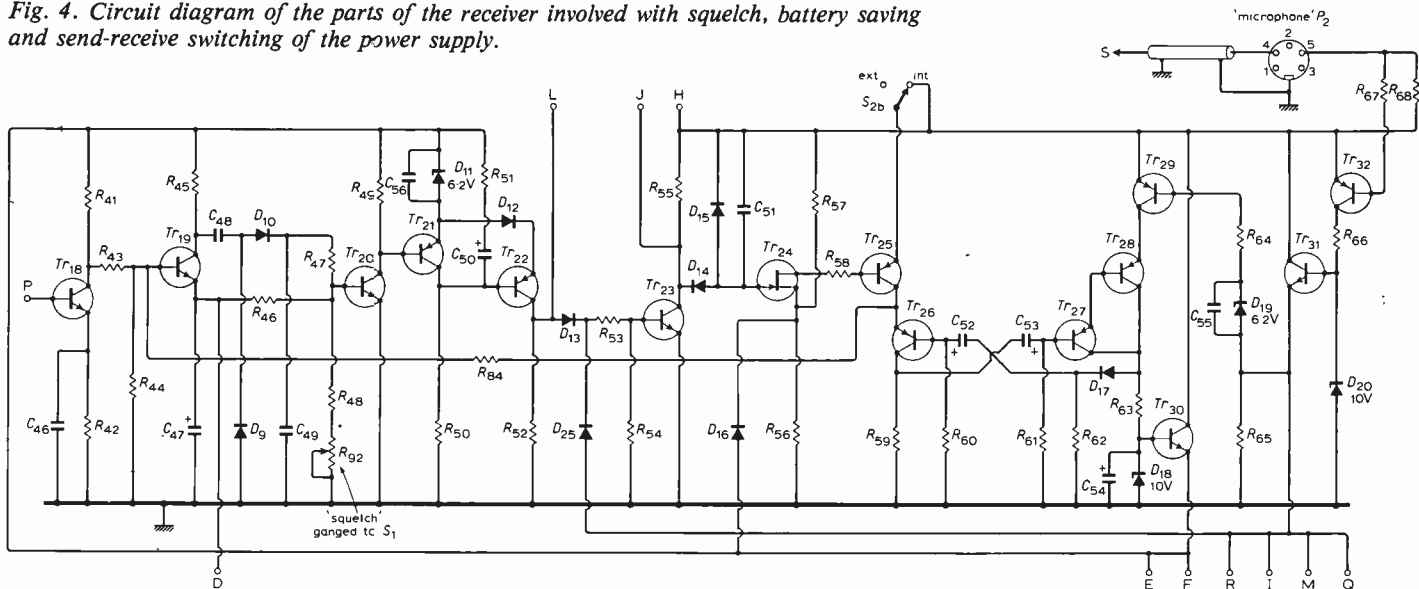

Fig. 4. Circuit diagram of the parts of the receiver involved with squelch, battery saving and send-receive switching of the power supply.



470kHz, which provides the main selectivity in the receiver. In turn, the output from the filter re-enters the i.c. at pins 10 and 11 to be amplified. After amplification the signal is rectified by an active detector within the i.c. and the audio output appears at pin 8 in the form of a positive voltage which goes more positive as the signal level increases. Following smoothing by  $R_{24}$  and  $C_{37}$  the output is used for the i.f. stage a.g.c. Transistor  $Tr_{17}$  limits any noise signal (impulses) on pin 8.

The i.c. contains all of the receiver audio amplifier except for a complementary output pair,  $Tr_{11}$  and  $Tr_{12}$ , and since the amplifier is also used as the modulator the i.c. needs to be continuously energized. The maximum permissible voltage at pins 2 and 9 is quoted as 9V in the data sheet,

therefore, the transmit and receive h.t. lines, which are stabilized at 9.5V, are used to supply the i.c. This avoids wasting power in a further zener stabilizer. Diodes  $D_1$  and  $D_2$  eliminate mutual interaction of the two supply lines. The first audio stage involves a differential pair and the action of the circuit (as d.c. negative feedback is concerned) is to maintain pins 4 5 at the same average potential. By appropriate choice of the resistor biasing components ( $R_{18}$ , 19, 32, 33 and  $R_{35}$ , 34) this action ensures that the quiescent voltage at the emitters of  $Tr_{11}$  and  $Tr_{12}$  remains at one half of the supply voltage. This is why pin 4 is fed from 'raw' h.t. and not from the stabilized line.

The audio output (up to 3W) is connected permanently to the primary of the modulation transformer,  $T_1$ . Isolation

of the loudspeaker when transmitting is carried out by the gate circuit comprising  $Tr_{13}$ , 14, 15, 16. Transistors  $Tr_{14}$  and  $Tr_{15}$  are the gate, the other two transistors being used to control the base currents. The magnitude of this base current determines the peak currents, which can be passed by the complete gate in its on state and this determines the peak audio power passed to the loudspeaker.

Reverse voltage breakdown in the emitter-base junctions of  $Tr_{14}$  and  $Tr_{15}$  during audio peaks causes a faint sidetone to appear in the loudspeaker, indicating correct functioning to the operator. Diodes  $D_6$  and  $D_7$  stop these breakdown currents from energizing the d.c. control transistors  $Tr_{16}$  and  $Tr_{13}$ . In addition the loudspeaker gate is used as a squelch gate, with the control

Fig. 5. Circuit of the r.f. section of the transmitter.

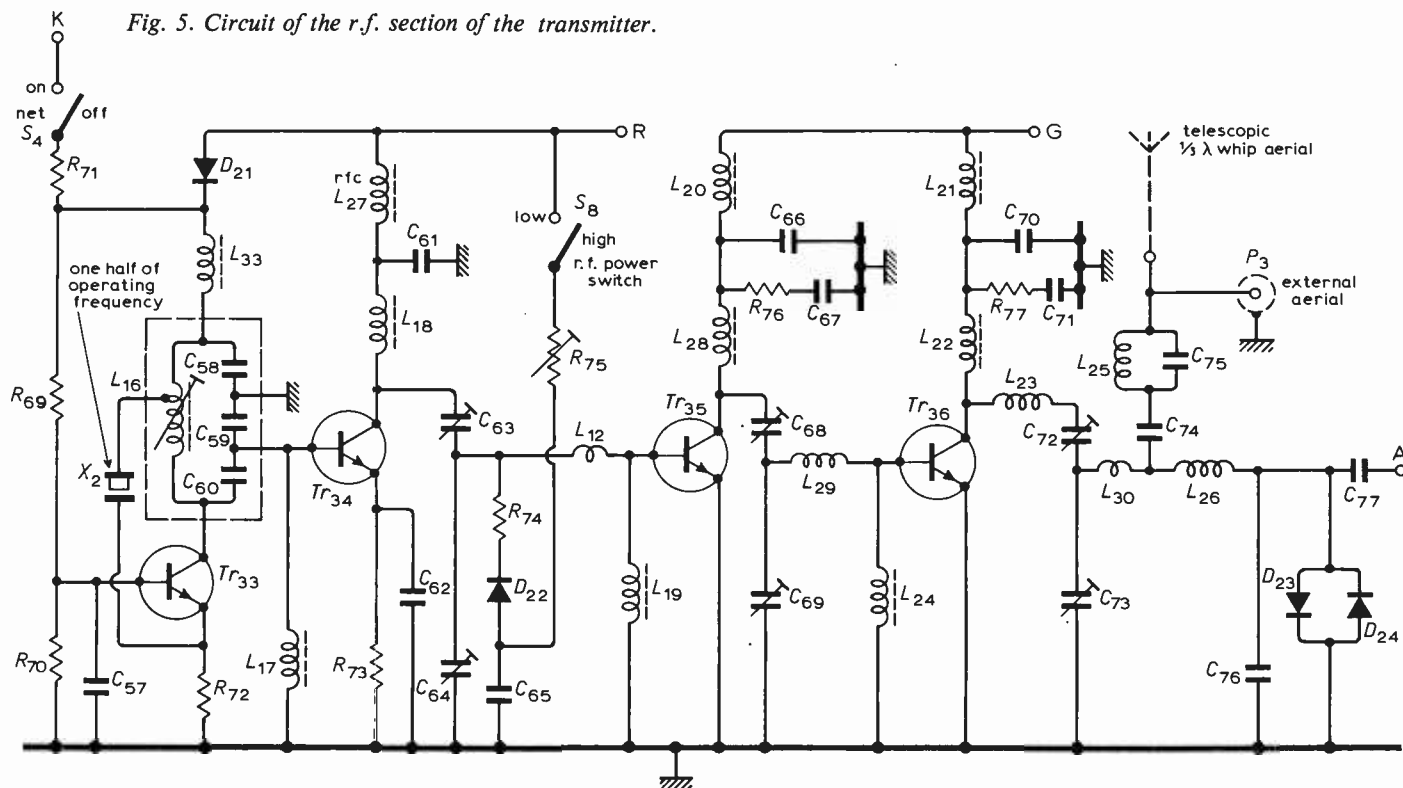

input connected to point *L*, and also it cuts out any clicks in the loud-speaker which might occur during sampling when the whole receiver is being switched on and off repetitively. Details of the power supply arrangements are shown in Fig. 3.

### Squelch, battery-saver, send-receive switching

Some of the circuitry in Fig. 4 could be omitted and one would still be left with a usable transceiver. The arrangement of  $Tr_{19}$ ,  $D_9$ ,  $D_{10}$ ,  $Tr_{20}$  provides noise compensation for the squelch<sup>4</sup>.

In the battery-saving circuit<sup>7</sup>  $Tr_{30}$  and  $D_{18}$  act as a voltage stabilizer for the complete receiver, and  $Tr_{32}$  and  $D_{20}$  do the same for the low-level transmitter circuits. Both of these transistors should have a low saturation voltage, so as not to waste battery voltage. If the current to  $D_{18}$  is interrupted, the receiver will be off and there are two reasons why this should happen. The first is if the transmitter is energized. Thus, if the microphone switch is operated (i.e. pin 5 of  $P_2$  connected to chassis),  $Tr_{32}$  is on,  $D_{20}$  passes current, and  $Tr_{31}$  applies stabilized h.t. to the transmitter.

This means that  $D_{19}$  no longer passes its breakdown current and  $Tr_{29}$  switches off, thereby turning off  $Tr_{30}$  and the receiver. The second reason is if the receiver is in the sampling mode and this is controlled by the gated multivibrator formed by  $Tr_{26}$  and the Darlington pair  $Tr_{27}$  and  $Tr_{28}$ . Transistors  $Tr_{25}$  and  $Tr_{29}$  form AND gates with  $Tr_{26}$  and  $Tr_{28}$  respectively. If  $Tr_{25}$  is off,  $Tr_{28}$  (and hence the receiver) stays on continuously; if  $Tr_{29}$  is off, the receiver stays off. Sampling can thus be inhibited if  $Tr_{25}$  is off (or indeed if  $S_2$  is switched to the 'external power' position). This happens either when a signal is being received, as indicated by the squelch threshold being exceeded and hence by  $Tr_{22}$  collector being at about +5V, or when transmitting. In either case  $D_{13}$  or  $D_{25}$  passes current into  $Tr_{23}$  base and in turn  $Tr_{24}$  is off and so is  $Tr_{25}$ . Moreover,  $Tr_{24}$  remains off for about thirty seconds after the squelch output ceases because of the time constant of  $C_{51}$  with the reverse leakage resistance of  $D_{15}$ .

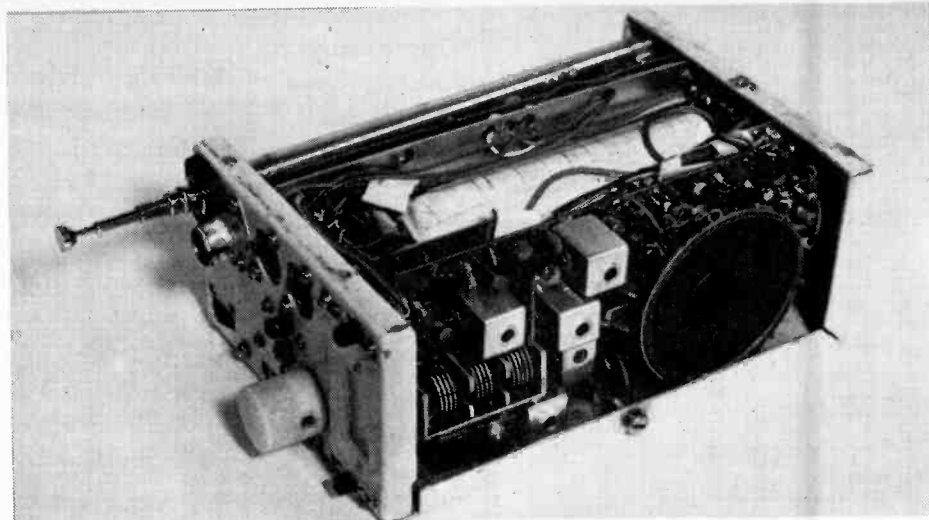

The transceiver with its cover plate removed showing the p.c. board, which carries the complete receiver, loudspeaker and tuning drive.

Fast rise and fall times are required for the receiver switched supply line if spurious effects are to be avoided, and  $D_{17}$  ensures this fast fall. The function of the components  $R_{51}$  and  $C_{50}$  is to make sure that  $Tr_{22}$  does not switch on momentarily as the receiver supply voltage falls to zero. If it did,  $C_{51}$  would be immediately recharged and sampling would never get under way. When  $C_{51}$  has recharged sufficiently to let  $Tr_{24}$  conduct slightly, regenerative action via  $D_{16}$  ensures a rapid transition by reducing the potential at the source of  $Tr_{24}$ .

### Transmitter

The radio-frequency parts of the transmitter<sup>5,6</sup> are shown in Fig. 5. Four stages are used beginning with an overtone oscillator,  $Tr_{33}$ , at one-half the operating frequency (see Fig. 1). The second stage,  $Tr_{34}$ , is the frequency doubler and this feeds the power output stage  $Tr_{36}$ , via the driver,  $Tr_{35}$ .

The 'output switch' is unusual and gives smooth control of the radiated power, without degrading the modulation characteristic. With  $S_8$  closed the dynamic impedance of  $D_{22}$  depends on the setting of  $R_{75}$  and a variable loss is introduced into the drive network for  $Tr_{35}$ . With  $S_8$  open,  $D_{22}$  has no effect and full power is obtained. Tuning-up is best carried out with each stage in turn beginning with the

oscillator and with an absorption wavemeter loosely coupled to the coil concerned. A  $75\Omega$  dummy load should be connected to the output socket,  $P_3$ , during this process, with a simple diode rectifier connected across it to give a comparative indication on a meter of the r.f. power output.

It is essential to realise that the tuning adjustments, which give maximum power output<sup>2,5</sup> will also give severe modulation distortion and hence serious, sideband 'splatter'. If at all possible an oscilloscope should be connected across the monitoring rectifier so as to be able to view the actual modulation waveform. Trimmers  $C_{72}$ ,  $C_{73}$ , and to a lesser extent,  $C_{68}$ ,  $C_{69}$ , should then be varied slightly from the settings which give maximum output, until good modulation linearity is achieved. The output carrier level will drop from about 2 to 1.5W, but the recovered audio voltage in a receiver will increase considerably.

The telescopic whip aerial is quoted as being  $\frac{1}{4}\lambda$  in length rather than the usual  $\frac{1}{2}\lambda$  since this gives a better match to the nominally  $75\Omega$  transmitter output impedance. It is assumed that the transmitter is initially tuned up as described above and with the whip aerial retracted.

The parallel tuned circuit formed by  $L_{25}$  and  $C_{75}$ , which is in series with the aerial lead is broadly tuned to 11MHz to help to decrease pick-up of signals at the first intermediate frequency.

The microphone pre-amplifier is shown in Fig. 6 and uses a complementary non-inverting feedback amplifier. In the author's equipment a surplus dynamic microphone (ex-Pye equipment) is used and the overall gain is such that full modulation (about 98%) is obtained when speaking about four inches from the microphone. If necessary the gain may be reduced by connecting a resistor in series with  $C_{83}$ . Great care is necessary in this type of equipment to avoid rectification of the intense radiated signal in the early audio stages. If this happens, high-frequency oscillations occur in the modulator and the transmitter is useless. The two r.f. chokes, together with  $C_{80}$  and

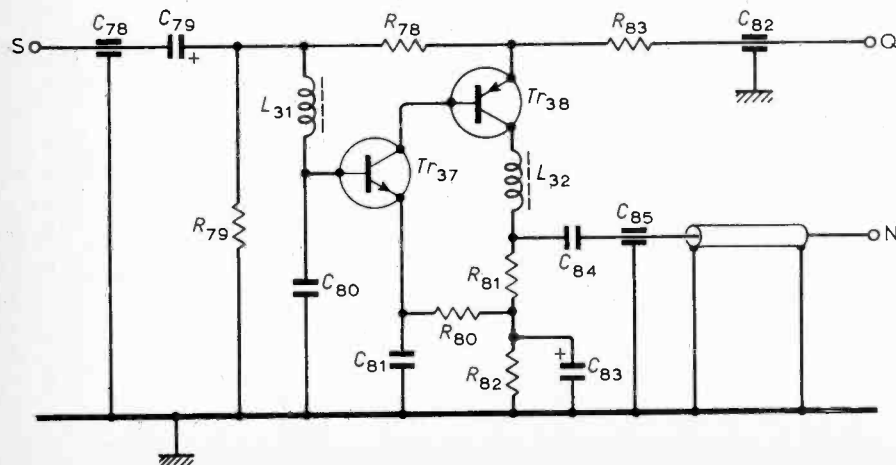

Fig. 6. Circuit of the microphone pre-amplifier.

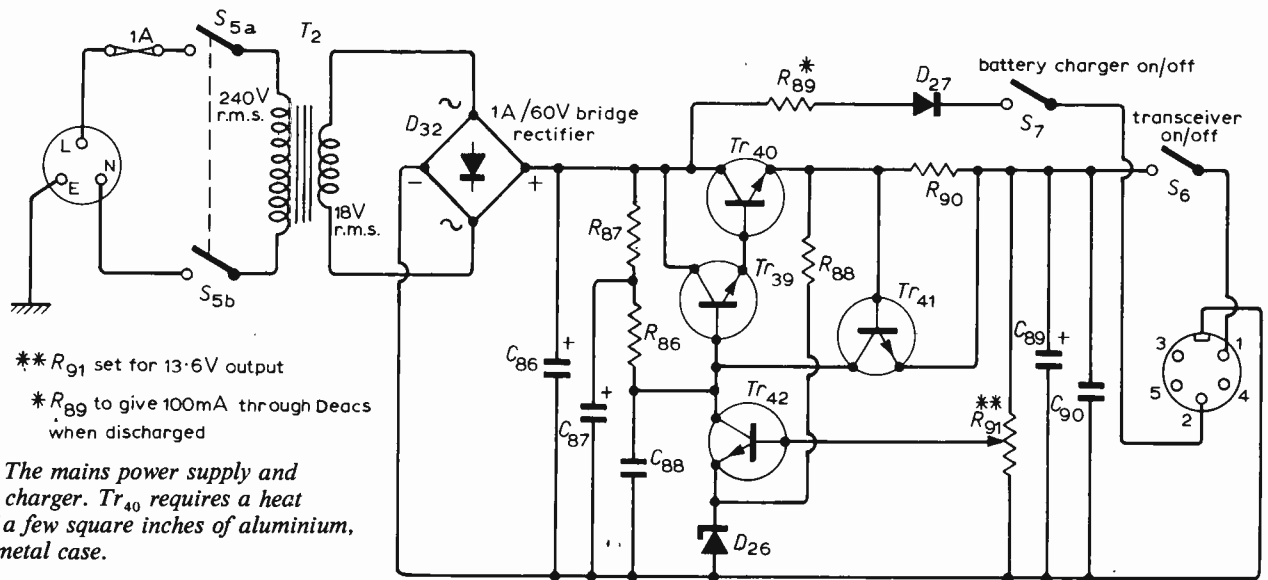

Fig. 7. The mains power supply and battery charger.  $Tr_{40}$  requires a heat sink of a few square inches of aluminium, or the metal case.

$C_{81}$  help to avoid this possibility, the choke in the collector lead to  $Tr_{38}$  being particularly effective. It is a wise precaution to build this pre-amplifier on a separate subchassis or even into a screened box.

**Construction**

With equipment of this complexity and compactness, it is considered superfluous and also too difficult, to give highly detailed constructional information. Potential constructors would no doubt have their own ideas on circuit modification and layout and this section therefore deals with the more general points.

The prototype was originally intended to have a variable frequency transmitter and therefore the packing density used in the actual transmitter p.c. board is far less than on the receiver. Two main boards are used, each measuring 14 x 6cm. and the microphone pre-amplifier uses a separate small board. One of the large boards contains all the circuitry in Fig. 5, while the other contains the circuitry of Figs. 2, 3 and 4 together with the receiver tuning dial assembly and loudspeaker. Epoxy-fibre-glass board was used with copper layers on both sides. One surface remains almost intact except for 2mm diameter discs removed around each component hole and is used as an earth plane. All components with one lead going to the negative supply line are soldered directly to this upper copper surface. The advantages over a single-layer board are as follows. (a) Very low inductance earth paths are obtained. (b) The wiring on the reverse side of the board is not too crowded. (c) The wiring is shielded from the components and vice versa. In order to save space, components are mounted with their axis perpendicular to the board and advantage is taken of coil 'cans' and large decoupling capacitors to shield critical components from each other. Plastic encapsulated transistors are more suited to compact forms of construction than the metal cased types and best of all for their small size are the Ferranti E-line devices.

**Accessories**

In order that the transceiver should live up to its design goal of being 'ever-ready'; two

other pieces of equipment are needed: a mains power supply and charger, and a similar unit for use in a car. Fig. 7 shows the circuit of the mains unit. Overcurrent protection is afforded by  $R_{90}$  and  $Tr_{41}$ ; with  $R_{90}$  equal to  $0.5\Omega$  the short-circuit current is limited to about 1A. A fairly high voltage is used for the transformer so that a resistor,  $R_{89}$ , can be used to supply a constant current of 100mA to the Deacs (Leclanché primary cells are not suitable) for charging purposes. This does mean however that a heat-sink is required for  $Tr_{40}$ . Diode  $D_{27}$  is included to avoid discharge of the Deacs if for any reason the mains supply to the charger is switched off with  $S_7$  still in the charge position.

The mobile power supply is shown in Fig. 8 and is used both to filter out noise on the car electrical system and also to limit the supply voltage to the transceiver to 13.6V. If a higher voltage than this is used the audio output pair are liable to be destroyed by thermal runaway; these are the only vulnerable parts of the unit however. If the car battery voltage is less than 13.6V,  $Tr_{43}$  is fully on and only about 0.2V is lost. This low voltage drop

is the main reason for specifying a germanium transistor for  $Tr_{43}$ . In order to provide charging facilities for the Deacs,  $Tr_{42}$  acts as a constant current source supplying 100mA to the Deacs whenever the car battery voltage is above the Deac voltage.

**Conclusion**

In terms of the initial design goal of a miniature complete two-metre station, the transceiver described in this article has proved very successful. It has given the author and his wife (G8ENO) many enjoyable contacts with stations in most parts of England and some in Europe when operated with a beam aerial on the house. With the whip aerial, ranges are less but distances up to 50 miles have been obtained.

**Components list**

If diodes or transistors have no type numbers indicated, almost any silicon planar types of appropriate power rating and gain will do. Thus for low power n-p-n transistors, the BC109 or ZTX302 families are appropriate and for p-n-p,

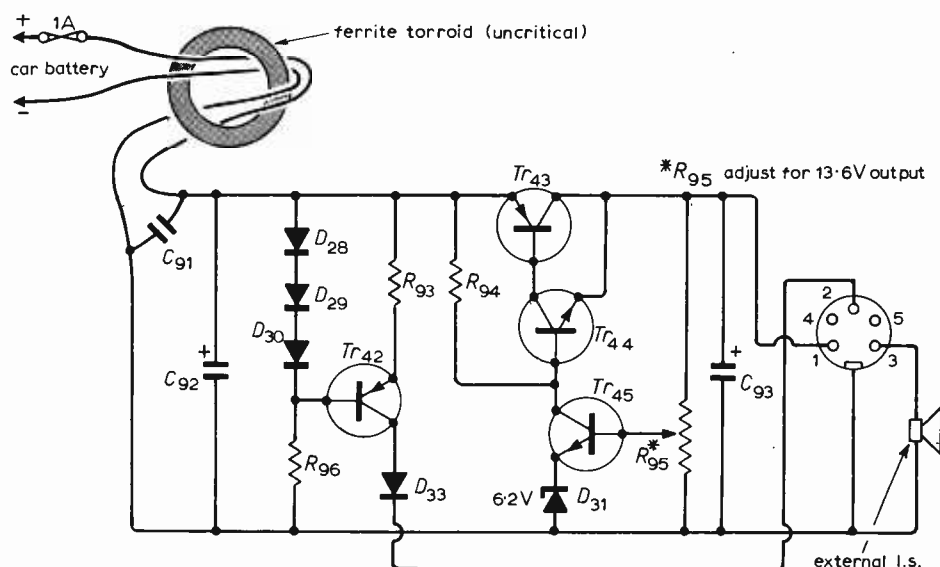

Fig. 8. Power supply and charging circuit for use with a 12V car battery.



the BCY70 or ZTX502 families. Suitable diodes are the OA202 or 1N914 types.

**Transistors**

1, 3, 4-2N5245	30, 31-2N744
5-E300	33-2N918
6, 7, 8, 9-ME3002	34-BFY90
10-2N3820	35-2N3553
11-AC187	36-BLY33
12-AC188	40-2N3054
24-2N3819	43-AD149

**Diodes**

23, 24-FD101 32-1A/60V bridge rectifier e.g. REC 41A

**Integrated circuit**

1-TAD100 (Mullard)

**Resistors**

1-10k	33-120	65-10k
2-100	34-6.8k	66-1k
3-100	35-18k	67-47k
4-10k	36-10k	68-100k
5-3.3k	37-560	69-5.6k
6-6.8k	38-2.7k	70-1.8k
7-22k	39-680	71-12k
8-10k	40-100k	72-470k
9-5.6k	41-10k	73-100
10-2.2k	42-1.5k	74-560
11-1k	43-15k	75-1k preset
12-5.6k	44-56k	76-10
13-1.5k	45-10k	77-10
14-470	46-22k	78-15k
15-560	47-12k	79-4.7k
16-820	48-4.7k	80-1k
17-150	49-68k	81-4.7k
18-39k	50-39k	82-4.7k
19-27k	51-1k	83-4.7k
20-150	52-22k	84-1.5M
21-220k	53-22k	85-5k 1in
22-150k	54-6.8k	86-750
23-8.2k	55-47k	87-22
24-8.2k	56-22k	88-270
25-390	57-18k	89-See Fig. 7.
26-1.5k	58-39k	90-0.5
27-6.8k	59-39k	91-See Fig. 7.
28-6.8k	60-68k	92-10k 1in
29-820	61-1.5M	93-10
30-180k	62-10k	94-820
31-100k	63-1k	95-See Fig. 8.
32-12k	64-100k	96-82k

**Capacitors**

1-5μ	48-1μ
2-470μ	49-1μ
3-470μ	50-2.5μ
4-470μ	51-10n
5-470μ	52-6.4μ/10V
6-5μ	53-2.5μ/10V
7-10μ	54-2.5μ
8-2000μ	55-10n
9-22μ (poly)	56-10n
10-1000μ	57-1μ
11, 12, 13-3/CG80-03	58-1000μ
(Wingrove and Rogers)	59-82μ
14-3 to 10μ	60-33μ
15-10n	61-470μ
16-15μ (poly)	62-1000μ
17-50n	63-3 to 15μ
18-47n	64-3 to 15μ
19-10n	65-470μ
20-30μ (poly)	66-470μ
21-470μ (poly)	67-10n
22-470μ (poly)	68-3 to 15μ
23-10n	69-3 to 15μ

24-470μ	70-470μ
25-100μ	71-10n
26-47μ	72-3 to 15μ
27-1000μ	73-3 to 15μ
28-10μ	74-470μ
29-470μ	75-47p
30-470μ	76-10μ
31-0.1μ	77-470μ
32-10n	78-1μ
33-50n	79-1μ/10V
34-4μ/10V	80-470μ
35-0.47μ	81-470μ
36-10n	82-1μ
37-10μ/10V	83-2.5μ/6V
38-50n	84-0.1μ
39-50n	85-1μ
40-3.3μ/10V	86-3000μ/50V
41-1μ/30V	87-200μ/50V
42-0.1μ	88-0.1μ
43-10μ/10V	89-100μ/25V
44-300μ/6V	90-0.1μ
45-300μ/6V	91-0.1μ
	(disc ceramic)
46-10n	92-100μ/25V
47-10μ/10V	93-50μ/25V

**Inductors**

If no reference numbers are indicated, the inductors are r.f. chokes consisting of two turns of enamelled copper wire (gauge unimportant) wound on a ferrite bead type FX1115 (Mullard). All others are 5mm internal diameter with appropriate ferrite core.

- 5½t, tap 1t from earthy end
- 12t
- 7½t
- 6t
- 5½t, tap 1t from earthy end
- 3½t
- 45.7cm of 38 s.w.g., close wound
- as 7 but centre-tapped and with 4 turn link wound at earthy end
- 25.4cm, 38 s.w.g. close wound

**Transformers**

- not critical. e.g. laminations 2.5 × 2.5cm of 8mm thickness. Primary 150t, secondary 370t using 32 s.w.g.
- not critical (240V r.m.s. to 18V r.m.s.)

**Crystal oscillators**

1-66.66MHz overtone type HC-18U

**References**

- Loudspeaker transmit/receive switch, D.A. Tong, *Wireless World*, October 1970, p.476.
- The G8ARV two-watt, two-metre transistor transmitter, D. J. Taylor, *Radio Communication*, Vol. 45, 1969, pp.840-5. The G8ARV two-metre portable receiver, D. J. Taylor, *Radio Communication*, Vol. 46, 1970, pp.664-669.
- Variable frequency oscillator, E. O. Seiler, *OST*, November 1941.
- Mobile 166MHz a.m. communications receiver, D. Singh, *Mullard Technical Communications*, Vol. 10, 1968, pp.14-29.
- V.h.f. transistor transmitters for a.m. and f.m. operating directly from vehicle batteries, L.M. Cash, *Mullard Technical Communications*, Vol. 10, 1968, pp. 2-13.
- Parasitic oscillations in v.h.f. power amplifiers, G. S. M. Teale, *Mullard Technical Communications*, Vol. 10, 1968, pp.279-284.
- A battery-saving circuit for portable communications receivers, D. A. Tong, *Wireless World*, March 1972, pp.124-125.

# H.F. Predictions — April

The charts here are based on an ionospheric index of 46, giving conditions similar to 1966. There are indications the index could be 10-12% higher than this, but with a similar situation last year the measured value was 10% lower than predicted. A higher index would be noticeably beneficial to the North Atlantic route. Seasonal ionospheric changes and longer days in the northern hemisphere flatten the Far East curve considerably. Evening fading is expected to be troublesome on all routes and a period of several subnormal days at the middle of the month looks likely.

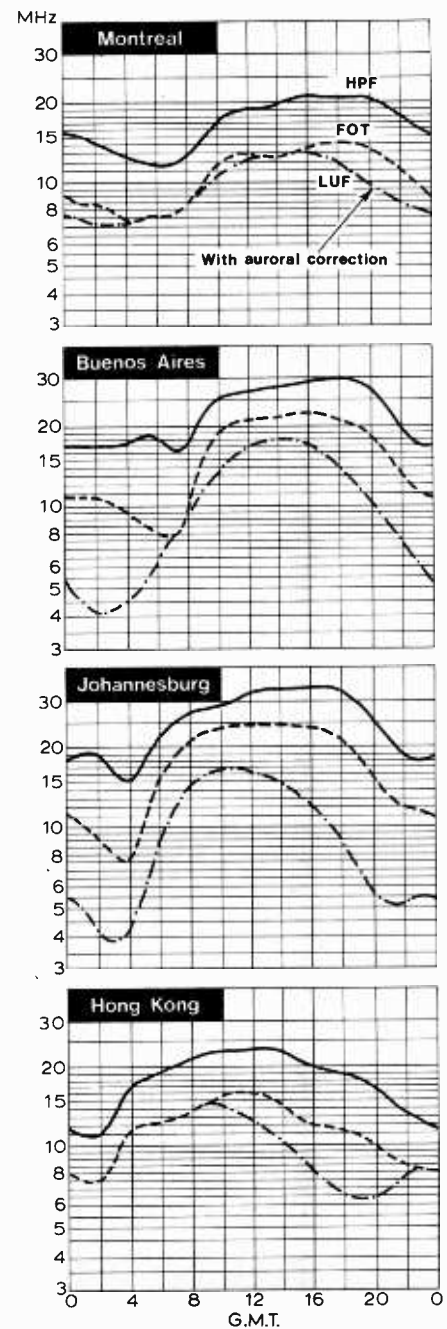



# The Electronic Retina

## One approach to optical character recognition

by N. A. Singer

With the advent of high speed computers novel methods of data input have been developed. One of these that has been working successfully is optical character recognition (o.c.r.), whereby 'raw' office documents may be used directly as input data. An o.c.r. system which was described in 1967 gave a tenfold improvement in error rate over a punched card system used to feed in a similar volume of data<sup>1</sup>. Modern systems have a worst case error rate of one character in  $10^3$ , for characters well below the E.C.M.A. (European Computer Manufacturers' Association) standard<sup>2</sup>, and of one in  $10^6$  or higher for characters meeting this standard. Reading speeds of up to 2400 characters per second are possible, and there are systems which can handle multiple printing 'founts' and even hand printed characters.

One of the basic methods of recognizing characters by reading machinery in the field today is called pattern detection. Pattern detection, or 'mask matching', can be thought of as an electronic extension of the mechanical process shown in Fig.1. Image information is compared simultaneously against all sets and values representing the patterns the machine can recognize. These stored sets of values are often called 'masks' because of this analogy.

In the design of o.c.r. systems, there are two main avenues of approach: the flying spot scanner technique; and the 'electronic retina'.\* In the flying spot scanner, the character is scanned using a spot of light in order to gather information about the outline of the character (Fig.2). The spot size and number of sweeps per character determine the number of data sampling points. At selected instants in time the reflectance is measured to determine whether the spot is viewing a black or white area. The basis upon which this decision is made varies from the simple to the very sophisticated. An example of the former is found in a simple reading machine, wherein a fixed voltage level is set as a threshold. Any point which is found to indicate less light than is fixed by this threshold is considered to be black. Perhaps the most sophisticated system of

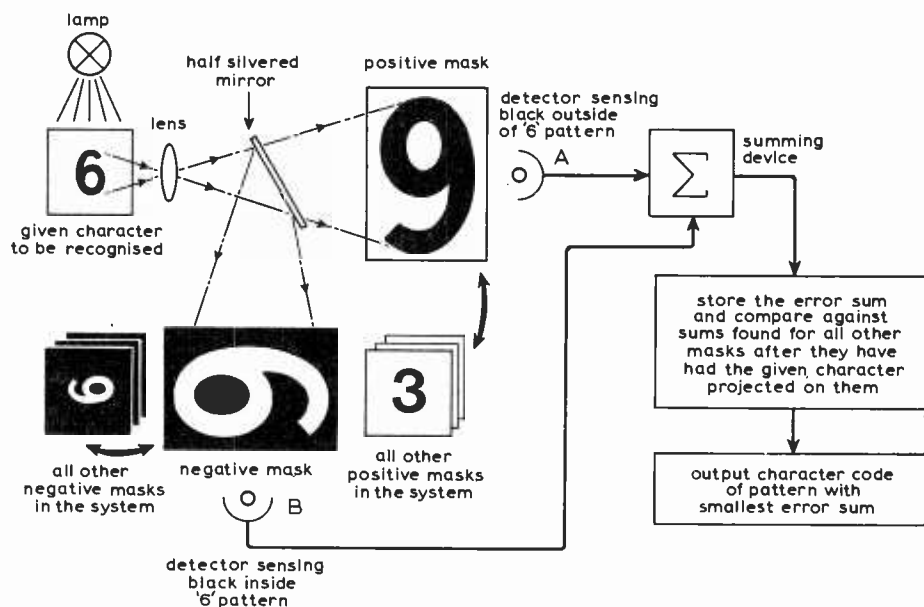

Fig.1. Basic process of pattern detection by 'mask matching'. Information from a scanner or electronic retina is compared simultaneously with all the sets of values representing the patterns the system can recognize. These stored sets of rules are often called masks because of this analogy.

this type to date is one which defocuses the spot and measures the average reflectance near the spot so that this value may be compared with that at the highly focused spot itself and a black-or-white decision made on a localized basis.

As soon as the black/white decision has been made, the scanner continues to the next point to make a similar decision. This process continues, covering an area roughly equivalent in width to that of the characters being read and a height of twice that of the character. (The extra height is made available to allow the character to be misplaced with respect to other characters in the line.) Each of the black/white decisions made is stored in a memory (usually consisting of digital shift register elements). The memory is then periodically examined by some form of recognition circuitry to identify the character.

The most general approach to determine the time at which the examination should be made is to look for a complete vertical column of sampling points that contain

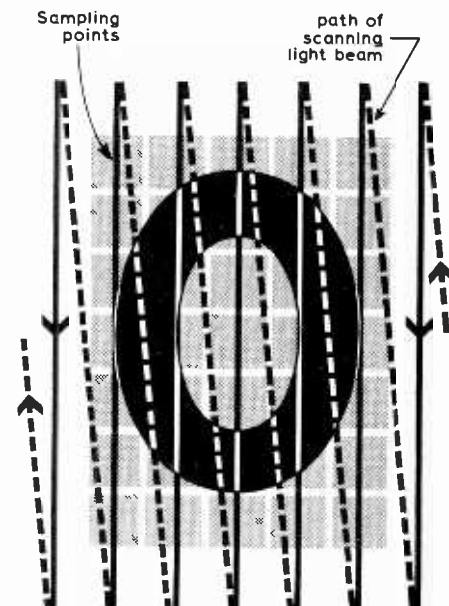

Fig.2. Flying-spot scanner principle. In practice much higher definition is used.

\*Electronic Retina is a trademark of Recognition Equipment Incorporated.

no black elements, indicating the white border circumscribing a character. This does, of course, force on the user of the scanner a requirement for high quality printing. For example, many typewriters, printing twelve characters to the inch with a fabric ribbon, cause most of the characters to touch. The scanner manufacturer's philosophy is that this constraint can be overcome by typing or printing only ten characters per inch and using 'one time' ribbons. This form of input usually implies the use of an electric typewriter.

Another approach is to set up a precise timing arrangement relying on the characters being spaced precisely ten to the inch and locating each character as a function of its distance in time from the first one.

Scanning techniques such as those described above will generally result in recognition rates varying from 200 to 2,000 characters per second, depending upon the complication (and thereby cost) of the equipment utilized. Non stylized characters such as those found on the usual office typewriter or high speed line printer are generally read with reject rates approximating to one character in 1,000 and error rates approximating one character in 10,000. These rates can generally be improved upon through the use of highly stylized characters. If one goes to the extreme case of the characters normally used for magnetic ink character recognition, E13B (as employed on British bank cheques) or CMC7 (devised in France by Compagnie Des Machines Bull and sponsored by E.C.M.A.), advanced scanners operating on them may achieve one-tenth of the error and reject rates respectively.

To understand, at least in part, the reasons for the scanner's rather unsatisfactory reading characteristics we must consider a television receiver. In this instance, a high resolution scanning spot is generated that is of constant size and continually forms a picture of unchanging dimensions. Yet, even with such extremely simple circuit requirements, the receiver is rarely able to display a circle as a circle. Extrapolating this to the scanner, usually a low resolution system, the non-stylized letter 'I' is readily distorted to the number '1', the 'O' to 'D', the 'B' to an '8' and so forth. The degree of distortion determines whether the character becomes a reject or a substitution. As a result of the scanner's rather unsatisfactory characteristics it was concluded, by a leading authority in the o.c.r. field in 1961, that the best approach would be to emulate nature and copy the human eye. The rod and cone sensor structure of the retina of the human eye would be analogous to a matrix of photocells, onto which the character could be focused. The cells being held physically constrained, their dimensions with respect to each other would be held constant, thus character distortion could not occur. Until the introduction of solid state devices, the large number of circuits required to build such a machine would have cost far more

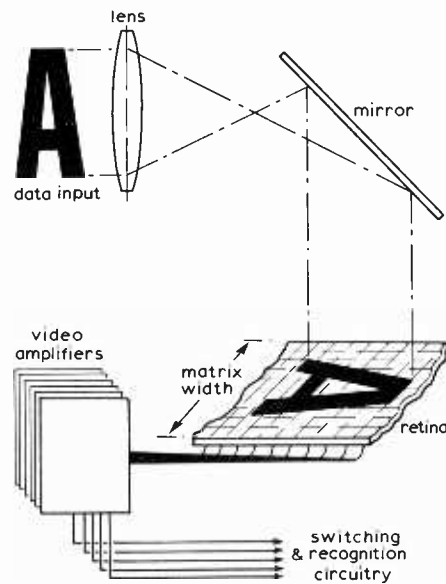

Fig. 3. The retina and associated optical and electronic components.

than the savings it could offer to the user. However in 1963, the first viable machine of this design was delivered on a production line basis to an insurance company in the U.S.A. The device was trade named the Electronic Retina and is generally referred to as the Retina, the entire recognition system of which the retina is but part being named the Electronic Retina Computing Reader.

The basic operation of the retina is simple. Its matrix, like the scanner, is slightly wider than one character width (Fig. 3). However, because it is not subject to distortion its height can be increased virtually at will. Current machines manufactured on this principle have a retina of 576 silicon photo-

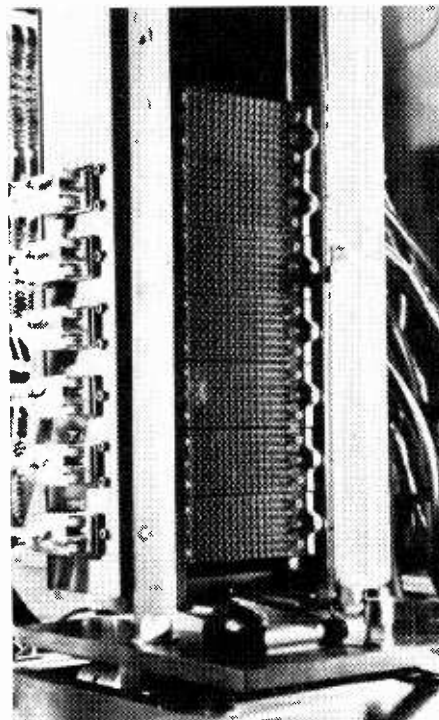

Fig. 4. Electronic retina, showing its construction from seven sections, one containing only two columns of cells forming the 'line finder'.

transistors arranged in a matrix 12 devices wide by 48 devices high. The optically projected and magnified character image is arranged to cover part of the matrix approximately 10 devices wide by 14 devices high. This design allows for vertical misalignment of characters up to one character height up or down.

The retina could use the techniques employed by a scanner making black and white decisions. In a simple case the output of each cell could be compared against the standard voltage and a black-or-white decision made. However, since structural data from the entire character are available simultaneously, the system was designed, without substantial cost increase, such that an absolute black/white decision was unnecessary. In this system the signals from the 576 phototransistors are amplified, each photocell signal by its discrete video amplifier, part of the amplifier's function being to provide a.g.c. and black level reference. The amplifier outputs are of analogue form.

From these outputs four decisions have to be made in the following order:

- 1 Where the character image is on the retina (vertical position).
- 2 If the character image is centred on the retina (horizontal position).
- 3 Which character of the recognition system vocabulary most closely matches the character image on the retina.
- 4 Whether there is sufficient difference between the best match (3) above and the next best match in the system's vocabulary (establish 'confidence level' of correct decision).

#### A working system

Eight o.c.r. systems based on the electronic retina principle described above have been installed in the U.K. An o.c.r. bureau system has been chosen as the subject for the following description because it gives the greatest insight into both the capabilities and the problems associated with a large system of this type. The equipment was installed in November 1970 and its use now extends over a twelve hour day, reading a vast array of printed or typewritten documents and pages ranging from card stock to airline tickets in thickness.

The recognition circuitry is basically a pattern detection system which looks for black and white in the correct cells of the electronic retina onto which the character under examination is projected. This is compared with stored patterns in its memory (or 'mask' bank). So long as the detected pattern is sufficiently like a stored one and different enough from the remainder a definite decision is reached. Those readers who have printing experience will have found difficulty in differentiating between, say, the character 'O' of one font and the '0' (zero) of another. In a similar fashion the accuracy of an o.c.r. system is improved by using only selected fonts and enabling only those fonts which are required under programme control from the controlling computer. This becomes even more critical when reading lower case or hand printed characters and punctuation as in

publishing work. Indeed it is perhaps the hall mark of an o.c.r. system that it can successfully read data for publication in a non-stylized font because of the reduced difference between (a) lower case characters, for example 'e' and 'a', and (b) punctuation characters, for example full stop and comma.

The system described here has 'masks' for the following fonts:

- IBM 1403
- IBM 1403 modified
- OCR B
- XO4 upper and lower case for publication work
- E13B (the font on bank cheques)
- 407E } fonts used on credit cards
- 7B }

(A hana-print option is available but is not fitted to this system.)

The first three of the above are non-stylized fonts and common typewriter fonts.

The remainder are special fonts for particular applications. It is a common occurrence for fonts to be intermixed on a particular document. A vertical bar (a black vertical line of particular width) or a code character may be used to switch fonts, again under programme control.

The o.c.r. system includes: a programmed controller (computer working on line) complete with magnetic tape transports, a line printer and other peripherals; a paper transport system; a document carrier for small items being read, and a page carrier for larger items, capable of handling a large range of intermixed sizes and weights of paper; a Retina and associated amplifier circuitry (Fig. 4); and a recognition unit with the 'masks', coding and other circuitry (Fig. 5).

The Electronic Retina, as already mentioned, consists of an array of 567 phototransistors (Fig. 6) arranged in a rec-

tangular pattern 48 units high (rows *a* to *z* and *aa* to *xx*) by 12 units wide. In addition it has a line finding extension of 8 units (rows) high by 2 units wide. The retina is slightly concave to ensure sharp focus of the image across it. Each n-p-n phototransistor is connected in the common emitter configuration, and its leakage is increased by light falling on it. In each of the 576 associated video amplifiers a nominal 526 kHz carrier signal is amplitude modulated by the output of the phototransistor. After passing through the a.g.c. stage the signal is demodulated and fed to video switches and character analysers, as shown in Fig. 5. The video switches (a diode switching matrix), under control of a six-bit 'centre' code received from the 'centre' storage and 'jitter' logic allow only a band of video outputs from the retina (16 high), to be fed to the amplitude correlators. The remaining outputs are unused.

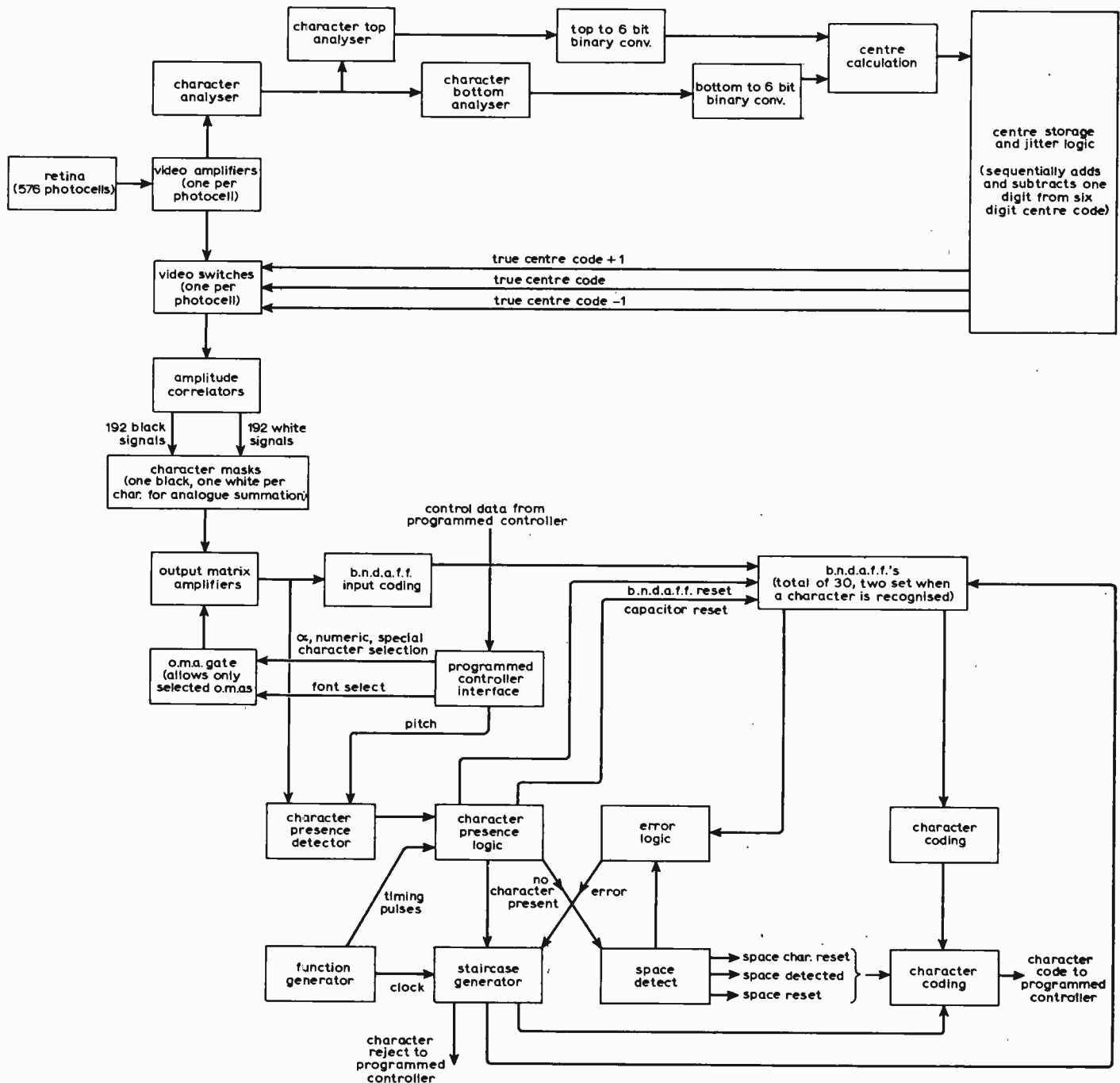

Fig. 5. Block diagram of recognition system based on the electronic retina.

In the character analyser each line of cells in the retina is examined for any black content. As a character passes across the retina (inverted by the lens system), approximately 16 out of 48 rows will have a black level signal present in them. Outputs from all 48 rows of the retina are now examined by the character top and character bottom analysers. The 45 AND gates which constitute top analysers give an output when the row under examination is black, the one below it is also black, and the one above it is white. This indicates that the top of a character is in that particular row of the retina. For instance the gate which analyses a top in row *q* of the retina will give a high output when there is a top in row *q* since all of its inputs will be high at this time, showing that row *p* is white, row *q* is black, and row *r* is black. Hence the criteria for a top of a character are a minimum of two adjacent black rows and at least one white row immediately above, except for row *b* which requires a minimum of three black rows with at least one white row above.

Bottom analysis of a character is provided by 44 AND gates and is similar to top analysis. The criteria for a character bottom are at least one black row and a minimum of three white rows immediately below it on the retina, with the exceptions that a bottom in *vv* only requires two white rows below and a bottom in *ww* only requires one white row below. It should be noted here that only the highest top and the highest bottom are selected within the logic and various conditions such as the character appearing too high or too low on the retina inhibit further processing of the video signals.

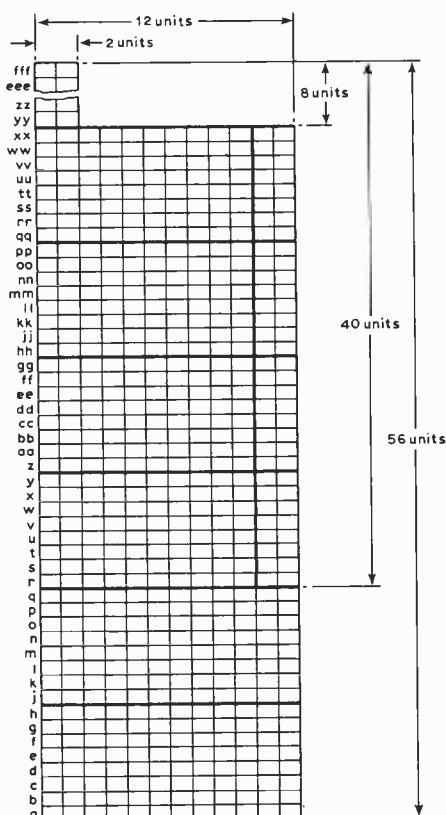

Fig. 6. Physical layout of the electronic retina.

Beloppet för ej gärdas					Anteckningar för ej gärdas i vita fältet nedan	
Härstadsdag	Per.	DIG	Kroner	öre	Kroner	öre
16.04.51	4		1.17	31	1.17	31



Fig. 7. Part of a Swedish bank giro form (read by an o.c.r. system) showing, enlarged, a comparison of a good and a deteriorated character — demonstrating the need to darken voids and whiten smudges.

The gate output (one of 45) indicating a character top in that row is now converted to a six-bit binary code and fed to the centre calculation circuitry. Similarly the line indicating the character bottom is also converted to a six-bit code and fed to the centre calculation circuitry. Here the two six-bit codes are added and shifted right one place, giving a centre code, corresponding to the centre of the character under examination of the retina. This six-bit code is now applied to the jitter control circuitry where, under normal operation the centre code is modified alternately one line up and one down. This technique gives a higher reading accuracy and will be described more fully later. The centre code is decoded to one energized line (out of 96) and applied to the video switches which gate only the selected area of the retina containing the character under examination to the recognition circuitry.

**Recognition circuitry.** Now 192 analogue signals (16 by 12 matrix), which correspond to the image of the character on the retina, are fed to the amplitude correlator circuitry, which compares each cell output to the surrounding 20 and modifies the apparent signal from each particular cell depending upon what is occurring in the cells surrounding it. This circuitry helps to whiten smudges on the paper and also to darken any voids contained in the character under examination (Fig. 7).

A complete pattern cannot appear around the cells near the edge of the retina but a phantom line voltage simulates, as required, the total output from the missing cells in these patterns. A total of 192 separate summing matrices obtain algebraic sums of the 20 cell patterns. That is, 192 identical patterns of 20 cells each (some of the cells are phantom) are summed and averaged. All phantom cells are considered

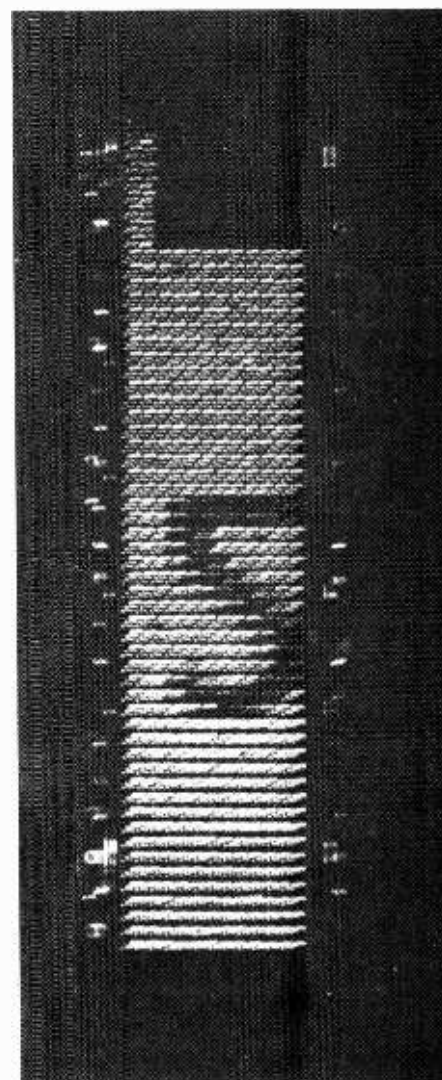

Fig. 8. A character image passing across the retina. The line finder extension can be seen at the top. Note that the character, a '2', is inverted by the lens system.

to be white. Further developments of this technique have been discussed.<sup>3</sup> The amplitude correlators give both a black and white d.c. output of approximately complement form for each cell in the selected area of the retina. These 192 black and 192 white d.c. signal lines are connected to the character masks. Two 'masks,' one black and one white, are related to each character. The white 'masks' contain resistors in the expected white areas of the character to which the 'mask' relates. The black 'masks' contain resistors in the expected black areas of the character. White amplitude correlator outputs are connected to black mask inputs and black amplitude correlator outputs to white mask inputs. This corresponds to placing a positive or negative grid of the character over the mask, much as a photographic negative might be matched with a print made from it. The black inputs correspond to a positive, the white inputs to a negative (see Fig 1).

If the character on the retina exactly overlays the mask, the sum of the outputs in that case is such to indicate a zero mis-match for that character mask. Any black detected in the white area of a mask, or any white detected in the black area of a mask results in a decreased d.c. output from the mask. Therefore, if a character does not exactly overlay the mask, a lower output voltage is obtained from the mask. Thus the character mask which least mismatches the character on the retina delivers the highest output voltage. More weight is placed on certain areas of a character by connecting these cell outputs to mask resistors of lower values (for example the tail of the letter Q). Each output line from its associated character mask (up to 360) is now applied to its unique output matrix amplifier (o.m.a.). If very high accuracy in reading is required only certain o.m.as are energized. For example, these may be alphabetical, numerical or a particular font required under control of the programmed controller.

When the output from a particular o.m.a. rises above a threshold level, character presence is detected, and a staircase generator is primed and, after a delay, activated. The circuitry which actually decides which character is present on the retina is termed 'best null detector and flip flop' circuitry (b.n.d.a.f.f.).

A uniquely coded pair of b.n.d.a.f.f.s (out of a total of 30) is set for a particular character, by an o.m.a. peak incremented by the staircase generator. Although the staircase generator may have been primed by a different o.m.a. signal, a larger peak following will be stepped up by the staircase and will set the two associated flip flops indicating the presence of a particular character. After these two flip flops have set, the staircase generator proceeds to count four more steps, in order to check if more flip flops are about to set.

If more than two b.n.d.a.f.f.s set then an error indication is generated, showing that there is insufficient difference between the outputs of two masks to ensure a reliable character decision. The outputs from the 30 flip flops are fed to the character coding

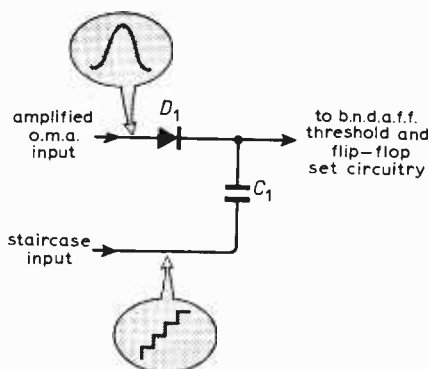

Fig. 9. Method of setting flip flops of 'best null detector and flip flop' unit (b.n.d.a.f.f.).

circuitry which supplies a b.c.d. code to the programmed controller.

A space is detected by allowing a time, equal to 170% of the time taken for a character to transverse the retina, to elapse after the previous character has been detected.

The code representing the character recognized by the recognition circuitry is fed to the programmed controller which stores it and after any required editing of a number of characters, this information is transferred to magnetic tape. Because characters are appearing on the retina at 500 microsecond intervals (for characters at 10 per inch) the computer must be interrupted during any edit routine by a signal indicating that a character has been recognized. This is a real time programming problem and the ways of overcoming this and other difficulties are beyond the scope of this article.

**The line finder.** The line finder extension of the retina (8 units high by 2 units wide) is employed only when the retina is used to read pages on the page carrier. This extension (seen in Fig. 8) is employed to detect a next line top below the line being read. When an end of line is detected a code

generated by the next line top logic which causes the page to shift to a new position. This ensures that the beginning of the next line will be in the reading area of the retina. Jitter is a technique which basically moves the 'window' on the retina, through which the character is viewed, one row of cells up and one down about the calculated centre. It has the effect of moving the character masks up and down over the unknown character while a decision is being made for the character under examination. The application of jitter in this system has been previously described, but its main advantage is the increase in reading accuracy. On badly formed characters this increase may be as great as 20%.

**Setting the b.n.d.a.f.f.** Fig. 9 shows the method of setting the b.n.d.a.f.f. flip flop, where the output is the sum of the o.m.a. peak plus the staircase input. Initially  $C_1$  is discharged, hence when the associated o.m.a. output rises,  $D_1$  is forward biased and  $C_1$  begins to charge. When the o.m.a. output has passed its peak and is falling away  $D_1$  is reverse biased, causing the peak value of the associated o.m.a. voltage to be stored on capacitor  $C_1$ . The peak o.m.a. signal primes the staircase generator which is triggered after a delay and this 'pumps up' the staircase input terminal, causing the output to rise in steps.

Referring now to Fig. 10, both the o.m.a. and the staircase input are buffered, before being applied to the summing circuitry previously described. The capacitor  $C_1$  (shown with the asterisk beside) is the capacitor which stores the peak o.m.a. value, and has the staircase input added to it. When the threshold of +6 V together with the forward volt drops of  $D_2$  and the emitter-base junction of  $Tr_3$  are exceeded, a negative pulse is generated as  $Tr_3$  turns on passing through  $C_2$  to turn off transistor  $Tr_4$ , setting the flip flop. The buffered outputs of this flip flop are available to drive associated coding circuitry. As previously stated, two b.n.d.a.f.f. flip flops are set for any particular character. The o.m.a. peak storage capacitor is reset after



Character reading system with electronic retina in tall central cabinet. On the left is a document carrier, and on the right a page carrier. The concertina-like structures shroud the character image from extraneous light.



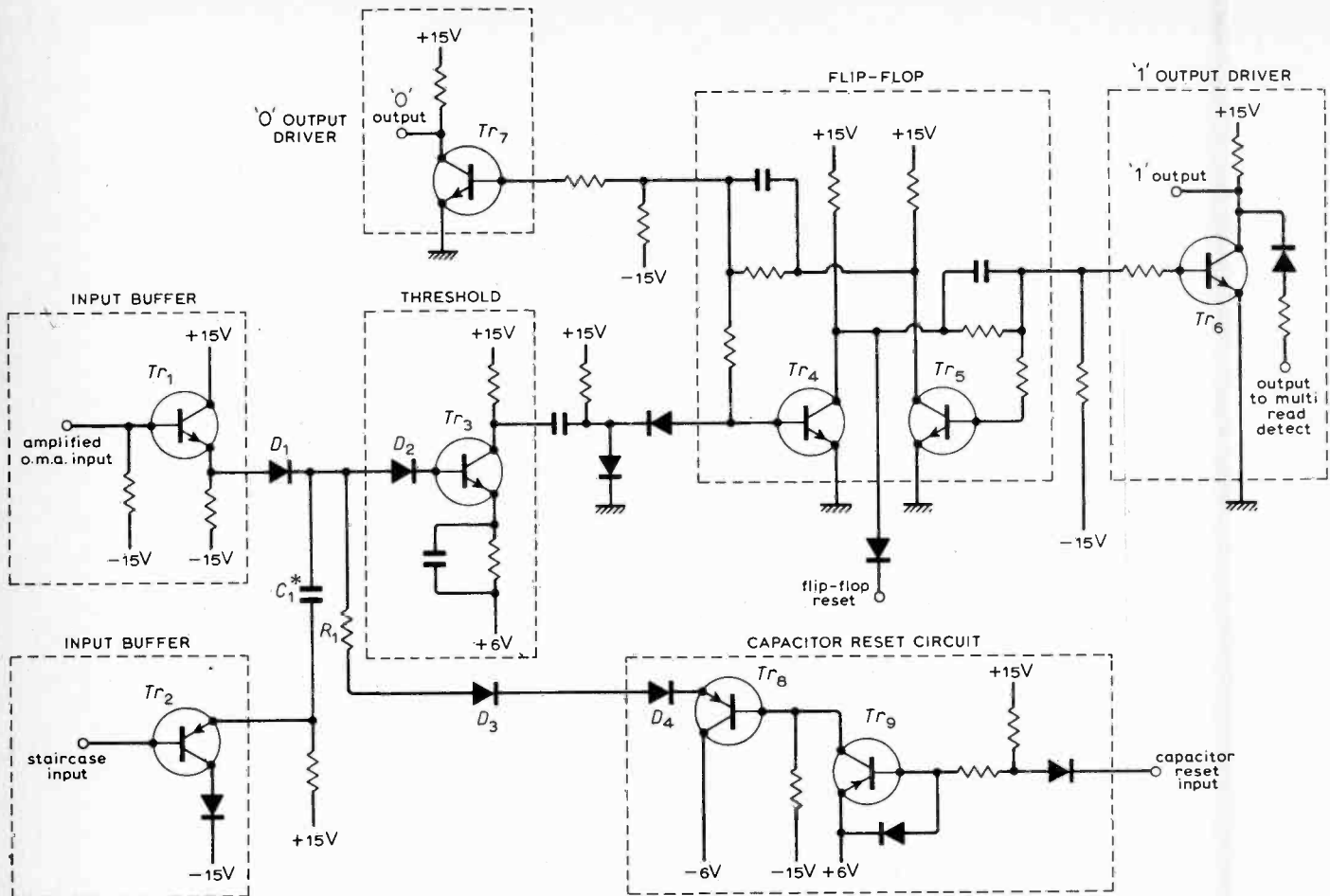

Fig. 10. Circuit diagram of a 'best null detector and flip flop' (b.n.d.a.f.f.).

a delay from the commencement of the staircase generation. This is achieved by applying a positive pulse to the capacitor reset input, which causes transistor  $Tr_9$  to turn off. As transistor  $Tr_9$  turns off  $Tr_8$  is turned on, causing capacitor  $C_1$  to discharge through  $R_1$ ,  $D_3$ ,  $D_4$  and  $Tr_8$  to approximately 5 volts. The output code to the programmed controller representing the character recognized is left available until another sample is taken. Immediately prior to this the b.n.d.a.f.f. flip flop is reset by applying a negative-going pulse to the flip flop reset input, which causes transistor  $Tr_4$  to conduct and  $Tr_5$  to be cut off, so resetting the flip flop.

**Acknowledgement**

Photographs are reproduced by kind permission of Optimization Services Ltd., Bromley, Kent.

**References**

1. "Optical Character Recognition" *Data Processing*, May-June, 1967.
2. E.C.M.A. Standard for Printing Specifications for Optical Character Recognition (May 1968). European Computer Manufacturers' Association, 114 Rue du Rhône, 1204 Geneva, Switzerland.
3. "Simulation of an Alphanumeric Character Recognition System for Unsegmented Low Quality Print" by J. R. Parks, J. Rosemary Elliott and G. Cowing. I.E.E.-N.P.L. Conference on Pattern Recognition, Teddington, 1968. I.E.E. Conference Publication 42.

# Conferences & Exhibitions

- LONDON**  
 Apr. 11-13 Finnish Embassy  
**Finnish Electronics Show**  
 (Commercial Section, Embassy of Finland, 53/54 Haymarket, London S.W.1.)
- Apr. 17-21 The Criterion  
**SEMINEX — Semiconductors Exhibition and Seminar**  
 (E. Steadman, 17 Dunganon Dr., Thorpe Bay, Essex)
- GUILDFORD**  
 Apr. 11-13 University of Surrey  
**Industrial Measurement and Control by Radiation Techniques**  
 (I.E.E., Savoy Pl., London WC2R 0BL)
- LOUGHBOROUGH**  
 Apr. 11-13 University of Technology  
**Digital Processing of Signals in Communications**  
 (I.E.E.E., 8-9 Bedford Sq., London WC1B 3RG)
- NOTTINGHAM**  
 Apr. 20 & 21 The University  
**Ion Movement in Anodic Films**  
 (Inst. Physics, 47 Belgrave Sq., London SW1X 8QX)
- SHEFFIELD**  
 Apr. 18-20 The University  
**On-line Computer Control Systems**  
 (I.E.E., Savoy Pl., London WC2R 0BL)
- SOUTHAMPTON**  
 Apr. 18 & 19 The University  
**Electrostatics Seminar**  
 (Inst. Physics, 47 Belgrave Sq., London SW1X 8QX)

- Apr. 25-28 The University  
**Computer Aided Design**  
 (I.E.E., Savoy Pl., London WC2R 0BL)
- TEDDINGTON**  
 Apr. 12-14 N.P.L.  
**Machine Perception of Patterns and Pictures**  
 (Inst. Physics, 47 Belgrave Sq., London SW1X 8QX)
- YORK**  
 Apr. 10-13 The University  
**Thin Films Interfacial and Surface Phenomena**  
 (Inst. Physics, 47 Belgrave Sq., London SW1X 8QX)
- OVERSEAS**
- Apr. 4-6 New York  
**Computer-communications Networks and Tele-traffic**  
 (Polytechnic Institute of Brooklyn, 333 Jay Street, Brooklyn, New York 11201)
- Apr. 6-11 Paris  
**Components Show**  
 (Société pour la Diffusion des Sciences et des Arts, 14, rue de Presles, 75 — Paris XV<sup>e</sup>)
- Apr. 10-12 Santa Barbara  
**Acoustical Holography**  
 (I.E.E.E., 345 East 47th St., New York, N.Y. 10017)
- Apr. 10-13 Kyoto  
**Intermag: Magnetics Conference**  
 (Intermag 72 Secretariat, KDD Research & Development Lab., 1-23 Nakameguro 2-chome, Meguro-ku, Tokyo)
- Apr. 19-21 San Diego  
**Microelectronics: Systems and Applications**  
 (Dr. D. C. Kalbfell, c/o Instruments, Inc., P.O. Box 10764, San Diego, CA 92110)
- Apr. 24-26 Boston  
**Speech Communications and Processing**  
 (C. Teacher, Philco-Ford Corp. 3900 Welsh Road, Willow Grove, Penna. 19090)



# Sound Pressure-level Meter

**A simple battery-operated instrument using a crystal microphone cartridge to obtain flat response in the range 20Hz to 5kHz**

by J. L. Linsley Hood

Many readers with an interest in the reproduction of recorded music must have attempted the construction of their own loudspeaker enclosures at some time or other. When this attempt is successful, it can be very gratifying, particularly if the enclosure design contains some elements of novelty, since the constructor can be reasonably certain that nothing quite like it exists anywhere else.

Unfortunately the matching of enclosures to the characteristics of driver units can present considerable difficulties even to the experienced. A complex design of enclosure, and the use of multiple drivers with electrical crossover networks makes the task of obtaining a clean sound even more difficult. While the ear is remarkably tolerant of non-uniformities in frequency response, provided that these are not too large in magnitude or steep in slope, the presence of unwanted large magnitude peaks in the frequency response curve is the undoubted cause of the 'booms', 'honks' and 'squawks' which can make unsuccessful systems so tiring to listen to. If these can be eliminated or lessened by the judicious use of some strategically placed damping material, or some adjustment to the dimensions of the enclosure, a great improvement can often be made to the quality of the sound.

Room acoustics play a very important part in the final performance of most loudspeaker systems, to the extent that an alteration in the position of the reproducer in relation to the walls and other large objects of furniture can sometimes alter the performance significantly.

## Use of impedance measurements

If the loudspeaker system is driven from a source which has an impedance higher than that of the loudspeaker, and is fed with a variable frequency signal from an a.f. signal generator or a test record, the frequencies of the cone, enclosure and sometimes even room resonances can often be identified by noting the frequencies at which peaks occur in the a.c. voltage developed across the loudspeaker terminals.

However, from personal observations, audible peaks in the sound output do not always show up as corresponding peaks in the speaker impedance curve, and humps in the impedance curve do not always

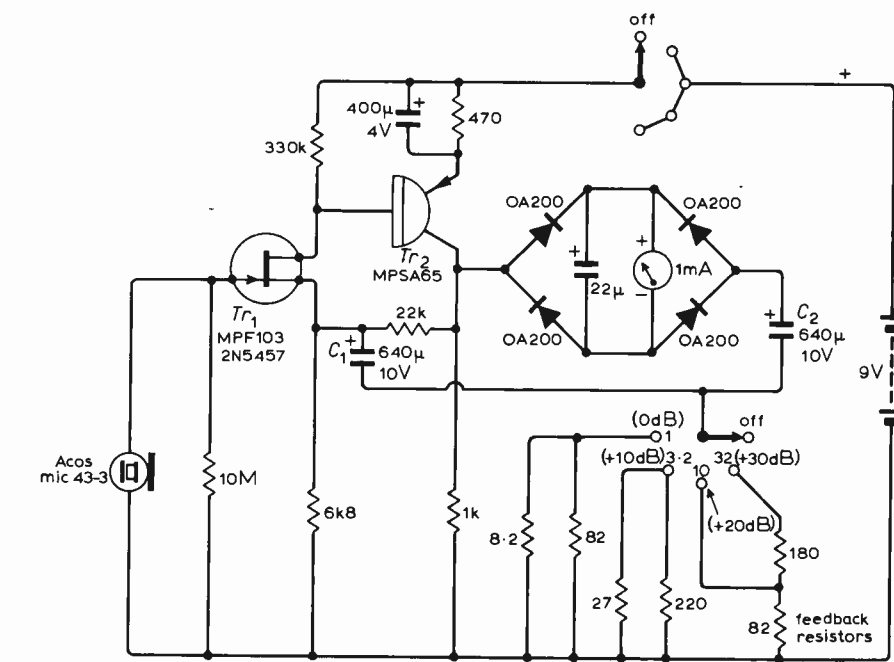

Fig. 1. Circuit of sound pressure-level meter.

result in an increase in sound output level at that frequency, when the loudspeaker is driven from an amplifier having a low output impedance.

For these reasons it is very helpful to the would-be loudspeaker constructor if he has a 'flat-response' sound measuring instrument to check the performance of his designs.

## Design of sound pressure-level meter

The measurement of sound levels is a complex task even with elaborate equipment and carefully designed anechoic environments, and any simple instrument used in uncontrolled surroundings is likely

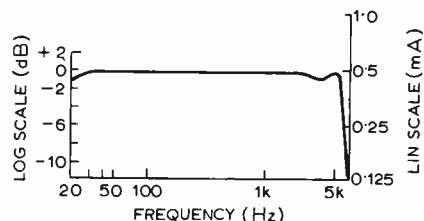

Fig. 2. Response of sound pressure-level meter using Acos MIC 43-3 crystal microphone.

to give imprecise and possibly misleading results. (However, measurement made out of doors with the speaker supported some feet above a lawn may not be too far removed from the anechoic ideal.)

We are concerned to measure the flatness of the speaker's output when it is fed with a constant amplitude sine wave. For this test the measuring instrument should have as flat a response as possible.

Pressure sensitive crystal and ceramic piezo-electric microphone units are relatively cheap and robust, and can provide a flat frequency response coupled with an excellent low-frequency sensitivity. They have a relatively limited high-frequency performance, but a flat response over the range 15Hz-5kHz is considered adequate for sensible test purposes outside the laboratory.

The instrument's circuit is given in Fig. 1. An Acos MIC43-3 crystal microphone unit is used with an f.e.t. amplifier. In order to avoid shunting the drain load-resistor of the f.e.t. a p-n-p Darlington transistor is used as the following amplifier stage. The measuring section is a negative feedback a.c.

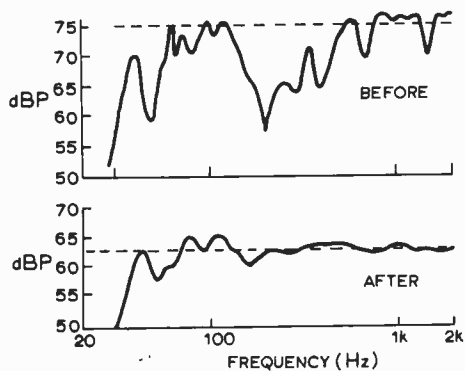

Fig. 3. Response curve, in the range 30Hz-2kHz, of experimental column loaded loudspeaker system before and after modifications.

millivoltmeter circuit. A d.c. feedback path is provided to the positive end of  $C_1$  to ensure stability of the d.c. working point. A five position wafer switch is used to give an 'off' position and four sensitivity ranges. To minimize switch-on meter 'kicks' the least sensitive range is used as the position adjacent to the 'off' position. Sensitivities are arranged in the ratio 1:3.2:10:32, which gives a decibel scale continuity of +30, +20, +10 and 0dB.

A 1mA f.s.d. meter is used for readout and the values of the feedback resistors chosen to give full-scale deflection sensitivities of 10, 32, 100 and 320mV at the gate of the f.e.t.

The '0dB' point was chosen arbitrarily as half-scale deflection on the most sensitive range, and the scale was then marked out with the range +6dB to -20dB (5% deflection). The microphone elements will inevitably vary somewhat in sensitivity, but with two of the three different units of this type tried the half-scale deflection of the meter corresponded on average to normal conversation at about six feet distance. (The third unit was about 50% less sensitive but had a rather better h.f. response.) This sound level is probably of

the order of +55dB with reference to the normal 1kHz '0dB' level of the Fletcher Munson curve, and this gives the instrument a usable range of approximately 35-92dB in sound pressure level.

The frequency response of the instrument was determined by the use of a high-quality headphone element in close proximity to the microphone, but separated from it by a  $\frac{1}{4}$  in layer of open-pore polyurethane foam to minimize air column resonances. The curve is shown in Fig. 2. This is in agreement with the response curve for the microphone capsule published by the manufacturers.

Finally, as an example of one of the uses to which such an instrument can be put, the response curve of an experimental column loaded loudspeaker enclosure, using a Wharfedale 'Golden' 10in RS/DD bass driver unit is shown in Fig. 3. The upper curve is the original performance following optimization by input impedance determinations, and the lower curve shows the response of the system after some modification to the column dimensions and the addition of suitable damping material. Although the final frequency response is still not as flat as desired in the two lower octaves, the large and unsuspected trough in the 200-400Hz region has gone, and the series of column resonance absorption slots filled in, with an audible improvement in the system performance. The penalty paid was an approximate 10dB reduction in overall sensitivity.

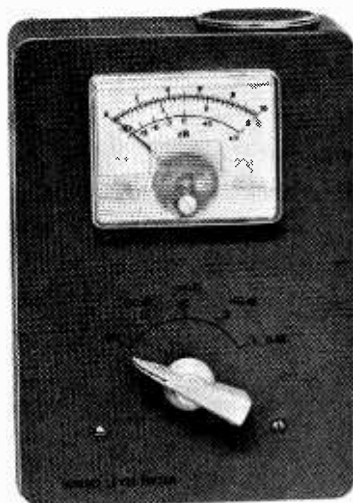

The completed sound pressure-level meter.

## Announcements

The Science Research Council has awarded a grant of £59,160 for research into galactic and extra-galactic radioemissions and other problems in radio astronomy under Professor Sir Bernard Lovell at Manchester University.

Two short courses in detection, estimation, and modulation theory will be presented by Professor Harry Van Trees in Brussels, Belgium; Part I, June 26-30; Part II, July 3-7. Further details are available from Dr. Harry L. Van Trees, 27 Grove Hill Avenue, Newtonville, Mass. 02160, U.S.A.

The 1973 German International Radio and TV Exhibition will be held in Berlin from August 31st to September 9th.

**Thomson-CSF Electronic Tubes Ltd**, Bilton House, Uxbridge Road, London W5 2TT, has been recently formed to promote the sales of Thomson-CSF professional electronic tubes in the United Kingdom. Mr. George W. Bailey is to take charge of sales activities.

GEC-AEI Telecommunications Ltd, P.O. Box 53, Telephone Works, Coventry CV3 1HJ, have changed the name of the company to GEC Telecommunications Ltd.

**Airtech Ltd**, Haddenham, Bucks, have completed negotiations with Standard Telephones and Cables Ltd, to take over all activities previously carried out by the Avionics Division of S.T.C. in respect of commutated aerial direction finder equipments.

Synergistic Products Inc., Santa Ana, California, manufacturers and distributors of numerically controlled wire wrap, dual in-line package insertion and printed circuit board drilling systems have formed an associate U.K. company, **Cavitron (Europe) Ltd**, 37 Thame Road, Haddenham, Nr. Aylesbury, Bucks, to market Synergistic products in the U.K. and to provide a contract numerically-controlled wire wrapping service. It will also be responsible for the installation (including operator training), and after-sales servicing of Synergistic equipment throughout Europe.

The Industrial Electronic Division of Thorn Bendix Ltd, based at Nottingham, has been merged with Thorn Automation of Rugeley to form a single company under the name of **Thorn Automation Ltd**.

Electrocomponents Associated Ltd, have formed a new company, **Electroplan Ltd**, 13-17 Epworth Street, London E.C.2, to distribute equipment and accessories in the instrumentation, process control and allied fields.

Photo Controls Ltd, Randalls Road, Leatherhead, Surrey, have been appointed U.K. distributors for **photocell lamps** manufactured by Moririca Electronics Ltd, of Japan.

The Electronics and Instruments Division of Bell & Howell Ltd, has acquired the sole U.K. marketing rights for the **Anadex Instruments Inc.** (California) range of industrial analogue and digital measuring, indicating and controlling equipment.

Martron Associates of Marlow, Bucks, has been appointed U.K. and Eire distributor for the **Yokogawa Electric Works (Japan)** range of instruments, including chart, X-Y and photo-recorders, electrical standards, panel meters, and digital and industrial instruments.

Techmation Ltd, 58 Edgware Way, Edgware, Middx. HA8 8JP, have been appointed exclusive agents in the British Isles for the range of **lasers** made by Hughes Aircraft Company and the Santa Barbara Research Centre's range of infra-red detectors.

ITT Components Group, Electromechanical Product Division, West Road, Harlow, Essex, are now responsible for the marketing and servicing of ITT **Metrix** (France) range of instruments in Britain.

**British Enkalon** announce that they are to acquire Akzo's right to a 60% interest in Brand-Rex Ltd, a company formed to develop, manufacture and sell wire and cable in Western Europe.

Arrangements have been made by Perfection Parts Ltd, of 59 Union Street, London S.E.1 for the marketing of a range of modular etching equipment, which is manufactured by **Transaco** of Stockholm.

**J.E. Sugden & Co. Ltd**, have moved from Bradford Rd, to Carr Street, Cleckheaton, Yorkshire, BD19 5LA. Tel: Cleckheaton 2501.

**Semiconductor Production Equipment Co. Ltd**, (Centronic), have moved to premises at 100 High Road, Byfleet, Surrey. Tel: Byfleet 48031.

**Hamlin Electronics** have moved from London to 14 New Road, Southampton SO2 0AA. Tel: 0703 32832.

The London sales office of **General Instrument Microelectronics Ltd**, is now at 57/61 Mortimer St, London W1N 7TD. Tel: 01-636 2022.



# News of the Month

## Jupiter fly-by

A spacecraft, Pioneer-F, is undertaking what is probably the most hazardous journey to be conceived by man. It will take the spacecraft close to Jupiter and then out of the solar system altogether, to carry on, as far as we know, for ever. The vehicle escaped from the influence of earth at 51,800km/s (32,000 m.p.h.) and became the fastest travelling object made by man; the orbit of the moon was passed only 11 hours after lift off. Four months after lift off the asteroid belt will be encountered and it has been calculated that the spacecraft has a good chance of getting through unscathed. So far it has been estimated that there might be 50,000 asteroids in the belt ranging from 770km (480 miles) to 1km (0.6 mile) in diameter though the danger presented by these is negligible. More hazardous is the unknown quantity of dust travelling at high velocity. It is thought that an area as large as the U.S.A., if placed in the asteroid belt, would receive impacts by eight particles with a mass of 1g or greater every second or a particle with a mass of  $1\mu\text{g}$  would pass through  $1\text{m}^2$  every month. The largest danger is formed by particles

with a mass of between 0.1 and 0.001g of which there are an unknown number. A particle with a mass of 0.01g (which travels at 54,000km/hr (33,600 m.p.h.) can perforate a sheet of aluminium 1cm thick and could therefore seriously damage the spacecraft.

About 300 days after launch Pioneer-F will pass behind the sun and communication difficulties will be experienced due to radio noise generated by the sun.

In just under two years' time Pioneer-F will have travelled about  $10^9\text{km}$  (620M miles) and will be in close proximity to Jupiter, the object of the mission, and the period of trajectory will pass at one Jupiter diameter, which is about 140,000km (87,000 miles), distance from Jupiter through a region of intense radiation. High-energy protons (hydrogen nuclei) and electrons in the belts could penetrate the spacecraft and destroy transistors and it is thought that the spacecraft could be crippled or data transmission could be cut off. However, one of the major objects of the mission is to assess the hazard

presented by Jupiter's radiation belts as this is a significant factor in planning future flights, not necessarily to Jupiter.

As the spacecraft is attracted by Jupiter's gravity velocity will increase to 128,000km/hr (78,000 m.p.h.) at periaapsis. During the Jupiter fly-by, if the spacecraft is still operational, an imaging photopolarimeter will alternate between taking polarization and intensity measurements, and taking pictures.

Signals from Pioneer-F during this phase will be received by N.A.S.A.'s deep space tracking network equipped with 64m (210ft) paraboloid aerials. The power of the signal received on earth from Pioneer's 8W transmitter will be about  $10^{-17}\text{W}$  and will take 45 minutes to reach earth. This time delay means that spacecraft control signals from earth will have to be sent 45 minutes in advance as Pioneer is controlled by earthbound computers and not on-board control systems.

About 30kg (65lb) of Pioneer's total weight of 260kg (570lb) is taken up with 13 experiments which will measure various aspects of interstellar space and the nature of the Jovian atmosphere; equipment is also included to investigate the asteroid meteoroids, celestial mechanics and S-band occultation.

Pioneer-F is the first spacecraft to be powered by a nuclear (plutonium 238 dioxide) generators. The four generators provided 155W at launch reducing to 140W at Jupiter and 100W in five years time.

The aerial system on the spacecraft employs a high-gain paraboloid, a medium-gain horn and a low-gain helix. Each of the aerials is always connected to at least one of the two receivers and can be switched to either by command from earth or automatically in the event of a receiver failure. It is of interest to note that although the spacecraft's travelling-wave tube transmitters produce only 8W in the S band the 64m (210ft) ground stations can radiate up to 400MW to ensure that the command signals reach the spacecraft at sufficient strength. The huge disparity between these powers is, of course, due to the difference in efficiency between the spacecraft's and the ground station's aerials and receivers and the need to keep the power consumption on board to a minimum.

Communications to Pioneer-F will be on 2,110MHz and from the spacecraft on 2,292MHz. The telemetry system is capable of 2,048 bits per second reducing to half this at Jupiter range.

As Pioneer-F swings by Jupiter (the gravitational pull) velocity will increase to 79,200km/hr (49,320 m.p.h.) reaching the orbit of Saturn in five years' time and Uranus in eight years' time; distance from the sun will then be  $2.9 \times 10^9\text{km}$  ( $1.8 \times 10^9$  miles). If Pioneer survives its encounter with Jupiter it will be possible to communicate with it although the transit time required for a signal will lengthen to hours and received signals will become so weak as to be unusable before the spacecraft crosses the orbit of Saturn.

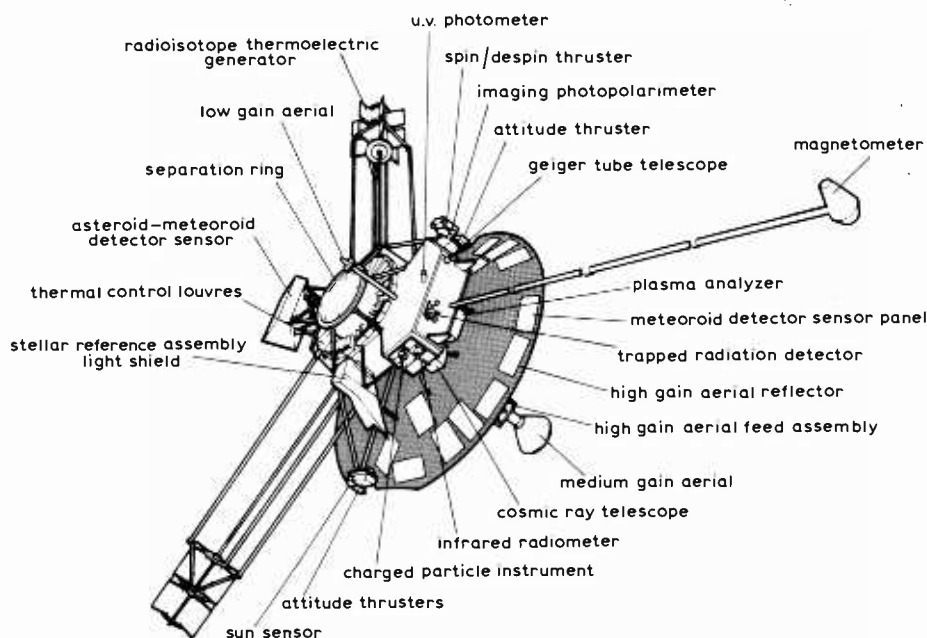

The first spacecraft to employ a nuclear power source, Pioneer-F, is now on its way to Jupiter.

After leaving interplanetary space and far out into interstellar space Pioneer-F should settle on a straight course heading away from the sun at a permanent 41,400km/hr (25,700 m.p.h.).

N.A.S.A. have allowed funds to cover the cost of the spacecraft and monitor and control functions up to three months after the Jupiter fly-by. But this period will be extended if useful information is still being received. The cost of the project is \$100M

## No more British i.c.s?

The closing down of the British integrated circuit manufacturing industry, following large losses over the past three years, is now being considered, to judge from a report in the *National Electronics Review* for January-February 1972. At a meeting of the National Electronics Council, attended by John Davies, Secretary of State for Trade and Industry, it was agreed "to invite the leaders of those branches of the electronics industry concerned with the development and production of integrated circuits to set up a Working Party to consider the implications to this country of the continuance or not of an integrated circuit capability . . .". This decision followed statements that Ferranti had lost £400,000 on i.c. production in 1971 and expected to lose £300,000 in 1972, and that the General Electric Company had lost £1M over the past three years. It may be recalled that in 1970 the managing director of Mullard stated that his company was then losing £1M a year on this manufacturing activity (see leader in *W.W.*, Sept. 1970 issue). One speaker at the meeting said that the British i.c. manufacturers ought to have financial support from the Government to enable the industry to survive. If the Government holds to its avowed policy of not helping "lame dog" industries (though this policy is said by some commentators to have collapsed as a result of the Clyde shipbuilding and Rolls-Royce settlements), this support will not be forthcoming and the British i.c. manufacturers may well have to cease production.

## Audio video dubbing

Sound facilities of a standard normally associated more with modern recording studios than 'on location' television work were recently used by Thames Television during the production of a series of 13 half-hour shows featuring Tony Bennett at the Talk of the Town, London. One objective was to make sound tapes suitable for issue later as stereo or mono discs.

A special sound mobile control room was used in conjunction with a new sound dubbing system 'Medway' developed at Thames to allow pictures recorded on v.t.r. machines at Teddington studios to be synchronized with sound recorded on location.

The new Thames mobile sound control room has a balancing area 17ft long with acoustic treatment and monitoring to full studio standard. Two Rupert Neve sound consoles provide 36 channels, and a new type of AKG spring-coil artificial reverberation unit provides echo on two channels.

The 'Medway' system allows separate music, effects and dialogue tracks to be recorded on the Scully eight-track machine for later dubbing, balancing and transfer to 2-inch quadruplex v.t.r. tapes. During sound dubbing use is made of a Sony helical scan v.t.r. to maintain atmosphere. The audio machine is interlocked first to the helical-scan machine and later to the quadruplex machine by means of a ten-bit binary address code. Dolby noise-reduction techniques were used during recording and balancing.

Technical controller of the series — which will be shown also in the United States — was John Tasker of Thames Television.

## Improving cinema sound

The Dolby noise reduction technique is now being applied to cinema sound. The effect of applying this technique to film is to make the sound quality of optical tracks comparable to that from magnetic tracks. Although background noise in modern films may go largely unnoticed — partly because of the visual 'distraction' from the sound and partly because of tailoring the reproduced sound — it is certainly obvious when you have been made aware of it, especially when the visual content is not so engaging or during 'quiet' passages. Because of the noise inherent in the optical sound track, a rapid reduction in amplitude with increasing frequency is the norm in cinemas, severely limiting realistic sound reproduction.

The noise arises basically from the granular structure of the film and from scratches and dust on the film.

To minimize the perceptibility of this noise the 'Academy' amplitude-frequency reproduction curve, which starts to roll-off at around 3kHz and at 8kHz is 15dB down, is widely used. In practice this attenuation can be as high as 25dB at 9kHz, provided partly by the screen (speakers are invariably mounted behind it), by a filter in the amplifier and, in some cases, by the slit size in the light beam passing through the sound track. Improving sound quality therefore means decreasing the h.f. attenuation as well as adopting a noise reduction technique. So

as well as installing noise reduction 'decoders' in cinemas Rank Film Equipment — who are worldwide distributors (excluding U.S.A.) of the Dolby cinema unit — also survey and improve the cinema equipment, for example removing filters, installing additional h.f. loudspeakers where necessary, and where existing h.f. units are behind the screen bringing them to the front. This last expedient decreases attenuation by 10dB for a screen in good condition and more for treated or nicotine-stained screens. After modifications, amplitude response should extend up to around 9kHz (or at least as far as the optics allow).

The Dolby unit installed, model 364, is an A-type playback unit, specially designed for cinema use. To get best effect, the film sound track must be 'encoded' using conventional Dolby A-type units, models 360 or 361, which increase the recorded level of low-amplitude signals. Although there are no films on release at present using the technique (at least in their entirety), this need not worry the film exhibitor because the cinema unit, which does the converse of the 'encoding' unit, will reduce noise on ordinary films. This is especially useful on old films, the noise level being reduced by 6dB. (Low-level signals are attenuated together with the noise but high-level signals are unaffected.) When operating with 'encoded' film, a reduction of 10dB obtains up to 5kHz, increasing at higher frequencies to a maximum of 15dB. If desired the Academy curve can be switched in on the 364.

Rank are adopting a rental rather than a leasing basis in offering this installation service to U.K. cinemas. Charge for the 364 is £2.74 per week, with an additional rental where extra speakers are used, subject to a minimum rental period of two years.

\*Academy of Motion Picture Arts and Sciences

## European communications satellite contract

A six-month study contract has been awarded to the Star consortium for a 'configuration definition study' concerned with telephone traffic between European countries and the transmission of television between members of the European Broadcasting Union via the proposed European communications satellite. The British Aircraft Corporation is the prime contractor and Lockheed Missiles and Space Company (California) are consultants to Star for the contract. The contract follows an earlier feasibility study. The Star consortium consists of: B.A.C. (U.K.), Contraves (Switzerland), Dornier (W. Germany), Ericsson (Sweden), CGE Fiat (Italy), Fokker (Netherlands), Montedel (Italy), Sener (Spain) and Thomson CSF (France).

At the same time the Cosmos space

consortium will be carrying out a 'configuration definition study' for the satellite. It is expected that the satellite will weigh about 400kg and will be capable of handling two colour television channels and several thousand telephone conversations. Marconi Space and Defence Systems are the prime contractors.

The Cosmos consortium consists of: GEC-Marconi (U.K.), Etudes Techniques et Constructions Aérospatiales (Belgium), Société Nationale Industrielle Aérospatiale and Société Anonyme de Télécommunications (France), Messerschmitt-Bölkow-Blohm and Siemens (W. Germany) and Selenia (Italy).

## Mullard awards to schools

Fourteen pupils from five schools, four of them in the Southampton area, received cash awards on behalf of their schools from Mullard Ltd at a ceremony held at the company's semiconductor plant at Southampton. The awards were made under the auspices of the Southern Science and Technology Forum by Dr Max Smollett, chief development engineer at Mullard Southampton, and were for the planning and content of technical or scientific projects which will be undertaken by the pupils concerned.

The idea of setting up Science and Technology Forums in various areas of the country originally came from Prince Philip in his capacity as chairman of the Schools Science and Technology Committee. The aim of the forums is to help teachers interest their pupils in the application of pure scientific knowledge to technology. The Mullard Awards were for those projects with an electrical or electronic basis.

Details of the first three of the ten awards are as follows: £20 for a logic display board and visual computer. Andrew Hicks (17) and Christopher Mullen (17) Barton Peverill School, Southampton; £20 for 'Poole Grammar School Computer'. Robert Cheetham (16) and Martin Hoyle (17) Poole Grammar School; and £10 for a wind gauge without moving parts. Peter Knight (18) Richard Taunton College, Southampton.

## Those pips

Some readers may have been puzzled by the recent change in the six-pip signal transmitted by the B.B.C. which has remained unchanged since it was first broadcast on February 25th 1924. The signal now consists of five short pips (100ms) followed by a longer pip (500ms). The start of the last pip marks the

beginning of an hour to plus or minus 20ms and the whole sequence is controlled by one of the atomic clocks at the Royal Greenwich Observatory.

The change was made on January 1st when Greenwich mean time was brought in step with atomic time. G.M.T. is based on the earth's rotation which is not constant, while atomic time does not vary. It will be necessary to occasionally alter G.M.T. by a positive or a negative leap second to bring it in line with atomic time. For convenience the Greenwich Observatory has decided to insert leap seconds on the last second of the last day in a month (preferably December or June).

In the case of a positive leap second 23h 59m and 60s will be followed one second later by 0h 0m and 0s. When a negative leap second is necessary 23h 59m 58s will be followed one second later by 0h 0m 0s.

## Semiconductor plant expands

In phase two of a development programme a further 90,000 sq.ft. has been added to Mullard's power and microwave semiconductor plant at Bramhall Moor Lane near Stockport. The total area now available to Mullard at Stockport plant is 160,000 sq.ft. and as a result a factory a mile away is to be closed. Mullard do not intend to take on more staff in the area at the moment. Of the 700 staff (40% women) more than 20% are qualified to H.N.C. or degree standard.

## Time-in-sync clock

The research institute of AEG-Telefunken has developed a clock (called the Telechron) that would seem to render obsolete all present clocks intended for domestic or even professional purposes. It is relatively inexpensive, it is portable, it can have the accuracy of an atomic clock and if switched off for a period and then switched on again will indicate the correct time within two seconds without resetting.

The clock relies on the fact that full information about every second, minute and hour can be transmitted in only 30Hz of bandwidth by existing television and radio transmitters in pulse coded form. No additional filters are needed at either the transmission or the receiving end. A clock would consist of a simple receiver, a shift register, a storage register, a digital display and some logic.

In the case of TV transmitters the time information would be inserted at the end of a frame.

## Communication '72

Communication '72, the conference and exhibition to be held in Brighton from the 13th to the 15th June, is to be opened by Earl Mountbatten. The conference, which covers military and civil radio communications (point-to-point, mobile and data) and associated test equipment has been jointly organized by *Electronics Weekly* and *Wireless World*. The conference programme and application forms for tickets for the exhibition (free) and the conference (£25) will be available from the exhibition organizers E. T. V. Cybernetics Ltd., 21 Victoria Road, Surbiton, Surrey, in April.

## Seminex

A series of seminars and an exhibition devoted entirely to semiconductors is to be held in London at the Criterion (Piccadilly Circus) between the 17th and 21st of April.

The exhibition will be a simple affair, each company being restricted to a maximum of 30ft of table space on which to display their wares; there will be no large stands.

The seminars have been divided into sessions by subject as follows: 17th a.m. linear i.c.s, p.m. hybrids; 18th m.o.s. all day; 19th memories all day; 20th a.m. digital i.c.s, p.m. opto-electronics; 21st discrete semiconductors. Tickets for the seminars cost £5/day and are available from E. Steadman, Seminex Booking Office, 17 Dungannon Drive, Thorpe Bay, Essex. (Tickets for the exhibition alone cost 40p.)

Companies taking part include: Emihus, Fairchild, Ferranti, General Electric, General Instrument, Intersil, ITT, Lucas, Microwave Associates, Microsystems International, Mullard, Plessey, RCA, Signetics, Texas Instruments, Toshiba, Welwyn Electric, and Westinghouse.

## Intercon '72

Nineteen U.K. electronics companies have registered for the I.E.E.E. '72 Intercon Exhibition and Conference to be held at the New York Coliseum from March 20th to 23rd. This will be the fifth year in succession that the Electronic Engineering Association, in co-operation with the Department of Trade and Industry, have organized a U.K. representation at the exhibition. U.K. companies taking part are: Avdel Marketing, Auto Precision, Birch Stolec, Bryans Southern Instruments, Cossor, Dek Printing Machines, Electrolube, EMI, Ferranti, FieldTech, Gordos, Jermyn, London Electrical Manufacturing, Marconi, Plessey, Vickers, Wayne Kerr and SDC Electronics.



# How to Simplify Logic Circuits

## Introducing the decision-accounts table

by N. Darwood\*

The theory of logical circuits is sometimes called switching logic. This is because the function of a combination of switches, such as is shown in Fig. 1(a), is easily described. Whether the components of which it is finally built are NAND, AND or OR gates or switches, the description of a logical circuit is the same. To explain: two switches in series make an AND gate, Fig. 2(a); two switches in parallel make an OR gate, Fig. 2(b). A switch which is short-circuit when 'on' and open-circuit when 'off' makes a logical inverter, Fig. 2(c).

Although the individual switches of a circuit may switch at electronic speeds, the function, i.e. the logic of the circuit, is described as though it is static and such that there is continuity across the circuit; the circuit is then said to be 'on'. For

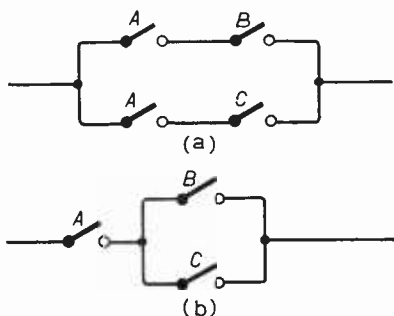

Fig. 1. All the possible switch states in these two (equivalent) combinations are shown in the truth table (first two tables in the text).

example, the logic of Fig. 1(a) is: either (A and B) or (A and C) which is written in shorthand as  $AB + AC$ . An instance of the usefulness of switching theory is to factorize  $AB + AC$  into  $A(B + C)$ , which is simpler to construct—Fig. 1(b).

In the paper and pencil analysis of a logic circuit, it is sometimes useful to consider all the possible combinations of states of the switches. In the circuit of Fig. 1(b) there are three switches, A, B and C. All the possible states are shown below. Also shown is the condition of the circuit in Figs 1(a) and (b).

A	B	C	$AB + AC$
off	off	off	off
on	off	off	off
off	on	off	off
on	on	off	on
off	off	on	off
on	off	on	on
off	on	on	off
on	on	on	on

Rather than having to write many 'on's and 'off's, it is usual<sup>1</sup> to use 1 for 'on' and 0 for 'off'. Whence the above table becomes

Truth table for circuits of Fig. 1

State	A	B	C	$AB + AC$
0	0	0	0	0
1	1	0	0	0
2	0	1	0	0
3	1	1	0	1
4	0	0	1	0
5	1	0	1	1
6	0	1	1	0
7	1	1	1	1

From the above table we can describe the logic of Fig. 1 as being on when the switches are in state 3 (i.e. 110 in binary form where the least significant bit is on the left), state 5 or state 7. This is the truth-table. One way of designing a logic circuit is to write out the truth-table which shows all the possible states of the switches, then to enter the required 'on' or 'off' circuit condition. Suppose a table as shown below is required.

Truth table 2

State	A	B	C	
0	0	0	0	0
1	1	0	0	1
2	0	1	0	1
3	1	1	0	0
4	0	0	1	1
5	1	0	1	1
6	0	1	1	1
7	1	1	1	0

The first step would be to derive a logical expression by extracting the states of the switches A, B and C that will produce an 'on' condition. From the table the circuit-on conditions are

states: 1 or 2 or 4 or 5 or 6

logical expression:  $ABC + \bar{A}BC + \bar{A}BC + ABC + \bar{A}BC$

Armed with this expression we can draw the logic diagram. There are five terms in the expression, hence five AND gates which feed into a five input OR gate are needed. The logic diagram is shown in Fig. 3. The logic diagram may now be converted into some other type of logic using, say, NAND

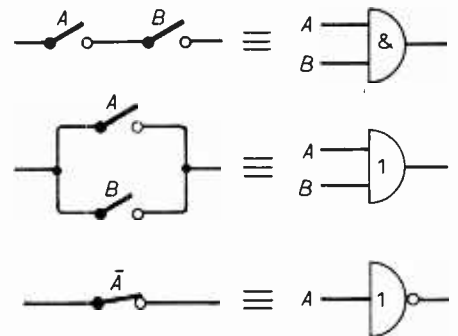

Fig. 2. In writing the logic diagram equivalent of switch diagrams, the notation shown is used.

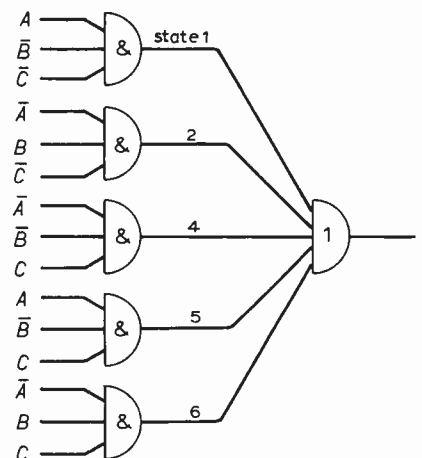

Fig. 3. To draw a logic circuit, the 'on' condition is normally written from the desired truth table. Truth table 2 gives an expression with five 'on' terms, realised by the logic gates shown.

gates. The conversion technique is a separate branch of logic circuit theory.

Returning to the logic diagram of Fig. 3, the circuit uses six logical elements. Using the truth-table or the rules of Boolean algebra (for example  $AB + AC = A(B + C)$ ;  $A + \bar{A} = 1$ ,  $A + A = A$ ) the full expression can be simplified, for example, to  $A\bar{B} + \bar{A}C + \bar{A}BC + \bar{B}C$ . The logic diagram of this expression, logically equivalent to Fig. 3, is shown in Fig. 4. Thus we can have two different, but logically equivalent, expressions one of which is simpler to construct than the other.

The question can be asked—are there other different ways a logical circuit can be built? Many methods exist for finding if a

\*Decca Navigator Co. Ltd.

simpler logical expression is possible, e.g. the Harvard method<sup>2</sup>; but they require a knowledge and a skill of Boolean algebra which usually only professional logic designers, or logicians, attain through constant practice.

**Decision-accounts table**

However, a new approach to the problem is being made, whereby not only are simpler expressions derived but also all the other equivalent expressions can be listed. This gives a complete analysis of the circuit. A table lists all the states to which a particular logic term, such as  $\bar{A}C$ , applies—in this instance states 4 and 6. (See logic tables opposite for three factors.) The table does not contain the states to which expressions apply, found by looking up the states for each term. To illustrate: the expression derived for Fig. 4 is

$$A\bar{B} + \bar{A}C + \bar{A}BC + \bar{B}C$$

Enter the tables at the section for three factors A, B and C, with each term, and extract the corresponding state, thus

- $A\bar{B} = 1,5$
- $\bar{A}C = 4,6$
- $\bar{A}BC = 2$
- $\bar{B}C = 4,5$

Therefore the expression, when implemented in hardware, will be on for states 1, 2, 4, 5 or 6, see Fig. 3.

Having found the states that apply to the circuit, to find logically equivalent expressions reverse the procedure by entering the tables with the states 1, 2, 4, 5 and 6, and extract all the terms that apply, as shown below.

**Decision-accounts table 1**

State no.						term found
1	2	4	5	6		
✓			✓			$\bar{A}B$
	✓			✓		$\bar{A}B$
		✓	✓			$\bar{B}C$
		✓		✓		$\bar{A}C$

Now as long as we take a combination of these terms that account for all the required states, then that combination will suffice. For example, the three terms  $\bar{A}B$ ,  $\bar{A}B$  and  $\bar{B}C$  suffice. The circuit, Fig. 5, uses less hardware than Fig. 4.

The above table is called a decision-

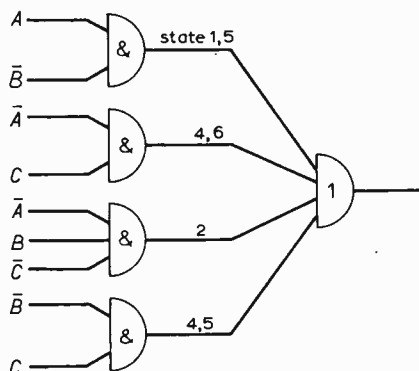

Fig. 4. The logic circuit of Fig. 3 could be simplified by using the rules of Boolean algebra on the logic expression of truth table 2, resulting in five instead of six gates.

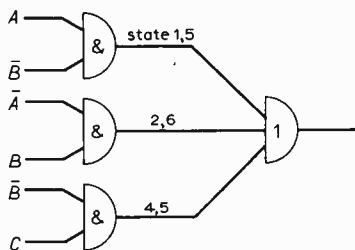

Fig. 5. To find other equivalent expressions or logic circuits of Fig. 3, a 'decision-accounts' table is compiled using logic tables which show all the terms that account for the required states. This allows the simpler circuit shown to be drawn.

accounts-table. In conjunction with the logic table, they form a Boolean expression simplification method<sup>3</sup>. The tables are easily derived<sup>4</sup>. This same decision procedure is useful also to programmers and systems analysts who have to formulate and programme complex logical decisions.

By extending the method we look for other expressions, perhaps simpler or perhaps just as simple but different, that will produce the same output for the same combinations of switch states. Because this is a new procedure it may be a little difficult to grasp. One logical law need be used to perform the manipulation. The law is  $X + XY = X$ , which allows us to eliminate a term if it is ORed with a factor of itself. The logic diagram of this law is shown in Fig. 6, in terms of switches and gates. If, for clarity, we label the rows of the decision-accounts table P, Q, R and S, then a more complex instance of the absorption law, as it is called, could be

$$PQS + PQ = PQ$$

Having drawn up the accounts table, we can now calculate the different ways of constructing the logic of Fig. 3. (The example is purposely obvious to show the reasoning). The accounts table, re-labelled, is

Row	State				
	1	2	4	5	6
P	✓			✓	
Q		✓			✓
R			✓	✓	
S			✓		✓

The first column is accounted for by row P, the second by Q, the third by R or S (= R + S) and the fourth by P + R and the fifth by Q + S.

Also we have to account for the first column and the second and the third, and so on. Hence an expression for this particular decision-accounts table could be

$$P \cdot Q \cdot (R + S)(P + R)(Q + S)$$

which can be expanded to  $(PQR + PQS)(PQ + PS + RQ + RS) = PQR + PQRS + PQR + PQRS + PQS + PQS + PQRS + PQRS = PQR + PQS$  (by application of the absorption law,  $X + XY = X$ ). The final expression  $PQR + PQS$  shows that either rows P, Q and R or rows P, Q and S may be used to construct the initial logic expression.

Because  $P = A\bar{B}$ ,  $Q = \bar{A}B$  and  $R = \bar{B}C$ , then one expression that could be used is

$$A\bar{B} + \bar{A}B + \bar{B}C$$

or, alternatively, because  $S = \bar{A}C$ , the following expression could be used

$$A\bar{B} + \bar{A}B + \bar{A}C$$

That the alternatives are equivalent to the original may be proved by the truth table,

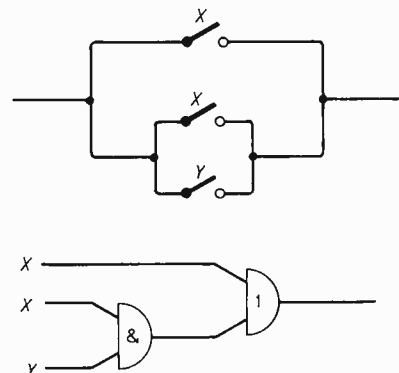

Fig. 6. In extending the decision-accounts technique the basic Boolean absorptive law  $X + XY = X$  is used, which allows elimination of a term which is ORed with a factor of itself.

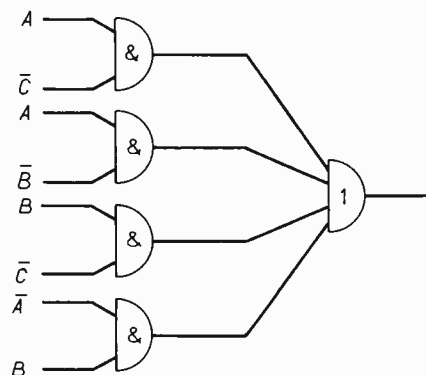

Fig. 7. In finding equivalent expressions for this circuit, the decision-accounts table 2 shows it can be achieved in either of two ways with one gate less.

or by showing via the logic tables that the three expressions produce the same states, which is the same thing.

**Further example**

Suppose the example is the circuit shown in Fig. 7; the Boolean expression is derived from the circuit as

$$A\bar{C} + \bar{A}B + \bar{B}C + \bar{A}B$$

Enter the logic tables at the section for three factors A, B and C to extract the states to which each term applies

- $A\bar{C} = 1,3$
- $\bar{A}B = 1,5$
- $\bar{B}C = 2,3$
- $\bar{A}B = 2,6$

Therefore the expression is ON for states 1, 2, 3, 5 or 6. Next draw up an accounts table. To ease the working the rows are labelled P, Q, R and S.

Logic tables

two factors	
0 = $\bar{A}\bar{B}$	0, 1 = $\bar{B}$
1 = $A\bar{B}$	0, 2 = $\bar{A}$
2 = $\bar{A}B$	1, 3 = $A$
3 = $AB$	2, 3 = $B$
three factors	
0, 1 = $\bar{B}\bar{C}$	2, 6 = $\bar{A}\bar{B}$
0, 2 = $\bar{A}\bar{C}$	3, 7 = $AB$
0, 4 = $\bar{A}\bar{B}$	4, 5 = $\bar{B}C$
1, 3 = $AC$	4, 6 = $\bar{A}C$
1, 5 = $AB$	5, 7 = $AC$
2, 3 = $\bar{B}\bar{C}$	6, 7 = $BC$
0 = $\bar{A}\bar{B}\bar{C}$	0, 1, 2, 3 = $\bar{C}$
1 = $ABC$	0, 1, 4, 5 = $\bar{B}$
2 = $\bar{A}B\bar{C}$	0, 2, 4, 6 = $\bar{A}$
3 = $ABC$	1, 3, 5, 7 = $A$
4 = $\bar{A}\bar{B}C$	2, 3, 6, 7 = $B$
5 = $A\bar{B}C$	4, 5, 6, 7 = $C$
6 = $\bar{A}BC$	
7 = $ABC$	

Decision-accounts table 2

Row	State				Term
	1	2	3	5	
P		✓		✓	$AC$
Q	✓			✓	$\bar{A}\bar{B}$
R		✓	✓		$\bar{B}\bar{C}$
S		✓		✓	$\bar{A}B$

The accounts table expression is

$$(P+Q)(R+S)(P+R)QS$$

$$= (R+S)QS(P+QR)$$

$$= QS(P+QR) = QSP+QRS$$

The final expressions show we can construct the circuit by either rows Q, R or S, i.e.

$$\bar{A}\bar{B} + \bar{B}\bar{C} + \bar{A}B$$

or, alternatively, from rows Q, S and P, i.e.

$$\bar{A}\bar{B} + \bar{A}\bar{C} + \bar{A}B$$

On looking back at the accounts table, it is intuitive that to account for each column ('on' state of the switches) at least once, then rows Q and S are essential (called prime-implicants in the literature). Rows Q and S account for states (columns) 1, 5, 2 and 6, leaving state 3 outstanding. With the prime implicants we may choose either row P or row R. Hence Q & S & (P or S) is the choice of decisions.

Readers may like to simplify and/or find alternative expressions for the following

$$AB + \bar{A}C + BC$$

$$\bar{A}\bar{B} + \bar{B}\bar{C} + \bar{A}B$$

$$A + \bar{B}\bar{C} + \bar{A}B$$

$$\bar{A}BC + \bar{A}\bar{B}C + ABC$$

References

- Boole, G. *Mathematical Analysis of Logic* (1847). Blackwell, 1965.
- Bowran, A. P., *Boolean Algebra*, Macmillan 1965.
- Hohn, F. E. *Applied Boolean Algebra*, Macmillan, 1966.
- Darwood, N., *Representation of Logic Tables*, *Electronic Engineering*, Jan. 1971.
- Darwood, N., *Simplification of Decision Tables*, *Computer Weekly*, 29 July 1971.

# Letters to the Editor

The Editor does not necessarily endorse opinions expressed by his correspondents

## Universal meter amplifier

A. J. Ewins's universal meter amplifier (February page 61) seems to be one of the more attractive of such designs. However, there are one or two points which worry me.

I am puzzled by his use of a half-rectifier/half-resistor bridge, instead of a full rectifier bridge, for the meter movement circuit. He has certainly reduced to a half the pedestal voltage to be overcome in the diodes, but to achieve this he has reduced the effective sensitivity of the movement to nearly a third. Thus, to achieve the same degree of accuracy at the lower end of the scale the open loop gain has to be half as much again as with a full bridge. This amounts to almost 5dB. (And to clinch the argument, suitable diodes, when bought in quantity, are much cheaper than resistors!)

It is true that his development of this part of the circuit in Fig. 4 (i.e. the insertion of  $1k\Omega$  between the two diodes) gains him more with a hybrid bridge than it would with a full bridge, but with the values given he is in fact only just regaining that 5dB anyway!

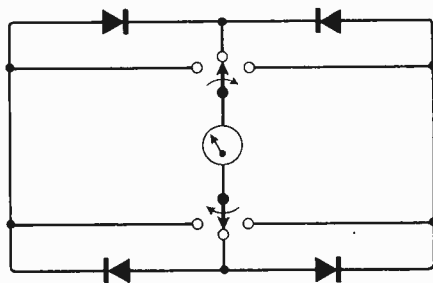

The full bridge circuit has other useful advantages. One of the weaknesses of the overall design is that the circuit cannot isolate a.c. from d.c. (a feature which is occasionally of great value). A two-pole three-way, switch inserted as shown at the centre of a full rectifier bridge circuit overcomes this difficulty together with that of polarity indication. Its positions represent d.c.+, a.c., d.c.-, and the need for a further diode, normally short-circuited, is obviated. The same switch assembly can cope with the switching for d.c. isolation shown in the

author's Fig. 5. The net result is very much more versatile for very little extra.

A further thought occurs to me. Surely what Mr Ewins is doing is simply to design, around a basic i.c., a high quality op-amp. Is it not possible that a standard package i.c. op-amp, with a couple of source followers tacked on the front, would do the job as well at considerable saving of money, space, and circuitry? If one were prepared to accept a minimum viable reading of 50mV at 100kHz (and 5mV at 10kHz) a simple 741 could be used as the centre of the circuits of Figs 4 and 6. Other i.c.s might, however, be more satisfactory.

Giles Hibbert,  
Oxford.

The author replies:

I am glad of the opportunity Mr Hibbert's letter gives me to comment on one or two further points of possible interest in connection with my universal meter amplifier design.

First, let me explain my thinking behind the use of the half-diode/half-resistor bridge. The amplifier was specifically designed around the Avo Model 9 meter movement which needs a  $10k\Omega$  shunt in order to achieve the required damping and sensitivity of  $50\mu A$ . Tapping the  $10k\Omega$  resistor at the centre only reduces the current sensitivity of the meter by half to  $100\mu A$ . Admittedly, in terms of the meter's basic sensitivity of  $37.5\mu A$ , the sensitivity of the circuit is decreased by a factor of  $100/37.5$ , i.e. 2.67, and if any other meter movement were used the circuit arrangement would not be as attractive. However, there is another point worth considering. Mr Hibbert says that by decreasing the sensitivity of the meter circuit the open loop gain of the amplifier has to be half as much again to achieve the same degree of accuracy at the lower end of the scale. In this he is not altogether correct since in this case it is *voltage* gain that is important and not current gain. By replacing two diodes with two resistors I have admittedly reduced the current sensitivity of the meter circuit, but I have effectively increased the voltage sensitivity, which is more important. (I am aware that the basic meter movement shunted by the  $10k\Omega$  resistor, tapped in the centre, has a decreased voltage sensitivity of  $37.5\mu A$

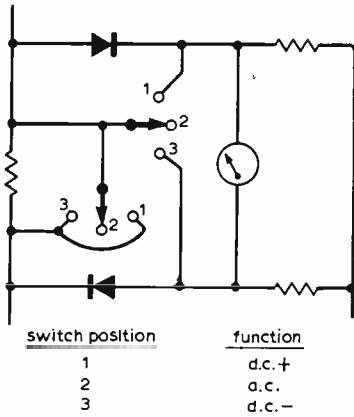

Fig. 1.

× 8333 ohms, which is approximately equal to 312mV, as opposed to its basic voltage sensitivity of 125mV. However, the removal of a diode and its associated, approximate, 600mV drop has the greater effect.) I am able further to effectively increase the voltage sensitivity of the circuit by forward biasing the two diodes in the circuit. It would not be possible to forward bias all four diodes in a full-bridge rectifier.

Mr Hibbert's suggestion for making the circuit give indications of d.c. -, a.c. and d.c. + is a good one. The use of the half-diode/half-resistor bridge does not preclude this possibility, see Fig. 1.

Mr Hibbert is quite correct in his assumption that the circuit is basically a high-quality operational amplifier, but the substitution of a standard package i.c. op-amp is not so straightforward. Apart from the fact that at the time of designing the circuit I had not had occasion to use a standard op-amp there is the point that they are awkward to balance for open- and short-circuit conditions, which is the requirement of the circuit of Fig. 3 of my article. A further, most important, point is that their output impedances are normally low and it is a requirement of both my final circuits that, for good linearity, the output impedances should be as high as possible before the application of negative feedback. However, since designing my original circuits I have given some thought to the possible use of standard op-amps.

Provided source-followers are used in front of the op-amp, giving high input impedances and eliminating the zero balancing problem, the appended circuits of Figs. 2 to 4 can be used for increasing the output impedance of the standard op-amp.

The circuit of Fig. 4 is the simplest because the TAA861 op-amp requires an external load resistor and it is a simple matter to make this a constant-current source. All three output stages will considerably increase the open loop voltage gain of the final circuits and it should be possible to increase the basic sensitivity of the amplifiers as Mr Hibbert suggests. I have recently constructed a millivoltmeter of 50mV sensitivity using the high output impedance circuit of Fig. 2 and a 709 op-amp. With a 1mA meter and a full-diode bridge the frequency response was from d.c. to 20kHz and the linearity excellent. Zero drift was no problem at all.

A. J. Ewens

### Imported equipment

Recent years have witnessed a large influx of foreign electronic equipment into this country especially in the audio field. While most of this equipment functions well most of the time, occasionally one comes across rather woebegone individuals who, in good faith, have purchased imported equipment which has, through no fault of their own, deteriorated and in many cases ceased to function.

Out of sympathy and understanding one offers to help find the cause of the trouble in the malfunctioning equipment, or to suggest that a recommended electronic repair firm would surely put the item back into good working order. This latter idea is usually greeted with varying degrees of derision, several attempts having been made in this direction. One learns that the estimates have been prohibitive to the extent that it would be cheaper to buy another unit or that the firm contacted have no knowledge of the brand concerned and hence will not undertake the repairs needed.

One returns to the former offer of help,

and is immediately confronted with a piece of equipment which certainly has an accompanying basic circuit diagram, but strangely no testing information or data. Closer examination reveals individual component brand names which are not unknown but on the other hand not easily obtained even via foreign component distributors.

What is one to do then? The first task is to discover working tolerances, especially with regard to the transistors used. Many foreign transistor manufacturers have agencies from where it might be reasonably expected to acquire information. One writes or telephones and discovers that only the types of transistor (which are limited) used in their own equipment are obtainable and information about even those types is far from complete. No, the types that one mentioned are not marketed in this country and no information is available other than from the parent company. How long must one wait before an answer of some description is received? Perhaps three months one is told. Net result, return to square one.

Substitution manuals are consulted next and the characteristics of the proposed substitution component carefully studied. All may be well but there is always the underlying feeling that this procedure is quite unsatisfactory.

Finally, through the good offices of the embassy or trade delegation one obtains the address of the company which manufactures the equipment. A letter is posted indicating what information is required and also mentioning that reasonable cost incurred by the company for a reply will be borne. One waits, and waits. A fortnight, a month goes by, two months, three months and yet four months and still no reply!

Is it that the exporters have so many very closely guarded secrets or that the foreign exporters could not care less about their equipment once it has left their shores?

S. Braidford,  
Wotton-under-Edge,  
Gloucester.

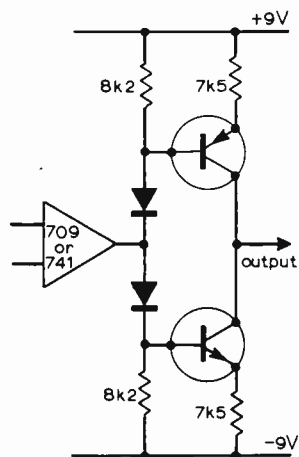

Fig. 2

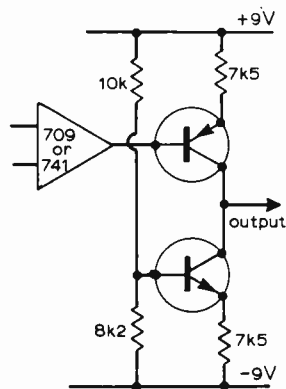

Fig. 3

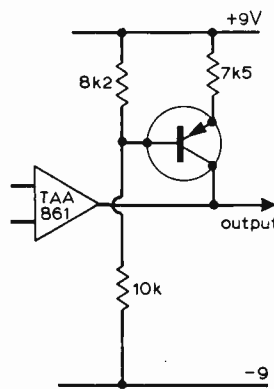

Fig. 4

Figs. 2-4 are possible high-impedance output stages using a standard op-amp at the front

### TV standards abroad

I would like to bring to the notice of your English readers who are contemplating emigrating to New Zealand the matter of television receivers. I have had quite a number of sets brought to me for conversion to N.Z. standards which have been sold, as suitable for our conditions, by English firms. Unfortunately this is often not easy or cheap and the owner generally has a set which is as dear as one on the market here and no spares available.

So for the information of your readers I'd like to pass on the details of our standards. We use 625 lines but only on v.h.f. Channel 1 (44 to 51 MHz), Channel 2 (54 to 61 MHz) and Channel 3 (61 to 68 MHz). Channels 4 to 9 are between 174 and 216 MHz so that a BBC2 u.h.f.

set is useless here. There are some European models which are usable and need minor adjustments to the three lower channels (for Channels 2, 3 and 4 European) but in our Channels 4 to 9 the channel switch only has to be set to the next highest channel to get satisfactory reception, e.g. EU7 is NZ6. Our sound i.f. is 5.5 MHz.

I am surprised that so little is known of the New Zealand situation in the U.K. and I have as mentioned come across people who have been told because the set operates on 625 lines in the U.K. it will work on 625 lines in N.Z. A similar situation would prevail for anyone going to Australia as they have the 625-line and 5.5 MHz system but have 13 channels some of these being in the v.h.f. f.m. band. Many of their channels are close to the N.Z. ones and sometimes cause interference even over 1200 miles. I have a very well known English TV in my 'junk box' which was bought in London for £50 and the only thing 625 on it is the label on the systems change knob. The 625 adaptor was not even in the receiver! Unfortunately when this was pointed out to the firm they just said they didn't accept responsibility as the 'salesman had left'!!  
B. E. Graham Goodger,  
Lower Hutt,  
New Zealand.

### Automatic telephone exchange

In the February issue I read with great interest the article on the design of a 'Miniature automatic telephone exchange' by G. F. Goddard, and was most impressed with its simplicity.

However, as all relays in use are P.O. type 3000, with open springsets, I would suggest that the method of switching on the mains power unit is changed as the existing arrangement is potentially dangerous.

Across the springsets of relays RLA and RLB both 245 V a.c. and 50V d.c. are to be found. In addition to the life of these contacts, RLA/1 and RLB/1 (live side 245V) being reduced unless heavy-duty

material is used, there is a very real danger of intending constructors receiving a nasty shock at mains voltage when working on the exchange, or alternatively shorting the 245V a.c. with the 50V d.c., due to the close proximity of this type of springset.

Although my suggested circuit modification requires the use of two additional relays (MSA and MSB) I feel the additional cost is more than offset by the improved safety factor as it is possible to mount these relays remote from the telephone switching relays. The type of relays used could be either heavy duty octal types, or mercury wetted contact relays, both having protective covers over their contacts, and a coil resistance of 3.3kΩ or more.

Also, the circuit diagram in Fig. 3 shows contact RLJ/3 as a normally open type. This would have to be normally closed otherwise on lifting the handset of any of the telephones, unselector U1 would continually drive as the coil of relay RLC has no path to -50V to operate on finding the calling extension.

N. Monk,  
Kettering,  
Northants.

### Incremental computer

The object of designing a hybrid computer is to improve the methods of processing information.

Accurate processing presupposes accurate input data — may we therefore point out that the development for which a grant has been given by S.R.C., to which you refer on p.112 of the March issue, is being carried out jointly by the University of Surrey (not Sussex as you stated) and Cranfield Institute of Technology.

W. F. Lovering & R. E. H. Bywater,  
University of Surrey,  
Guildford.

### Stereo decoder

Readers who have built the phase locked stereo decoder (Sept. 1970) may have noticed the decoder will 'blink' while the

receiver is being tuned. This is annoying when making fine tuning adjustments: e.g. during mono reception the decoding process is allowed with deterioration in s/n ratio; and during stereo reception, if tuned, the decoder momentarily resorts to mono operation.

The fault is caused by large d.c. changes (generated at the f.m. detector during tuning) being differentiated by C<sub>5</sub> and thus 'fooling' the in-phase lock detector IC<sub>3</sub>.

Fortunately the cure is simple: a 47,000pF capacitor should be added in series with R<sub>35</sub>.

P. Lacey,  
Crediton,  
Devon.

## Books Received

**Radio Data Reference Book (3rd edition)** by G. R. Jessop contains data presented in the form of graphs, tables and charts with only sufficient text to permit its effective use. The aim is to provide as wide a range of material as possible, which if sought by the normal means would involve a lengthy search through many volumes. It has been assumed that the reader will have sufficient fundamental knowledge for the direct application of data and where theoretical information on any subject is required the reader is referred to the appropriate reference books. A section contains a comprehensive list of frequencies allocated to radio and TV broadcasting stations in the United Kingdom, channel information on world television systems and amateur frequency allocations in the U.K. Pp.150. Price £1. Radio Society of Great Britain, 35 Doughty Street, London WC1N 2AE.

**Radio, Television and Audio Test Instruments (2nd edition)** by Gordon J. King is essentially a practical guide and is written with the emphasis on application and testing methods. In some cases it has also been necessary to consider various design and circuit features, so that the reader may fully appreciate the scope and diversity of application of the instrument. Chapter subjects include d.c., a.c. and electronic meters, signal generators, oscilloscopes, and component testing. There is also a comprehensive section on instruments for colour television and audio measurements (new to this edition). Most chapters have been modified from the first edition and some have been rewritten. Pp.199. Price £3.80. The Butterworth Group, 88 Kingsway, London WC2B 6AB.

**The Arlington Dictionary of Electronics** takes a middle line between oversimplified definitions and definitions which, while complete are highly technical. The terms included cover a wide range of electronic systems and networks (active and passive networks, control and telemetry systems, analogue and digital computers and communication systems) and also touch on applications in fields such as data processing, acoustics and medicine. Mathematical descriptions are provided where helpful and there are numerous pictorial representations and circuit diagrams. Pp. 171. Price £3. Arlington Books (Publishers) Ltd., 38 Bury Street, St. James's, London, S.W.1.

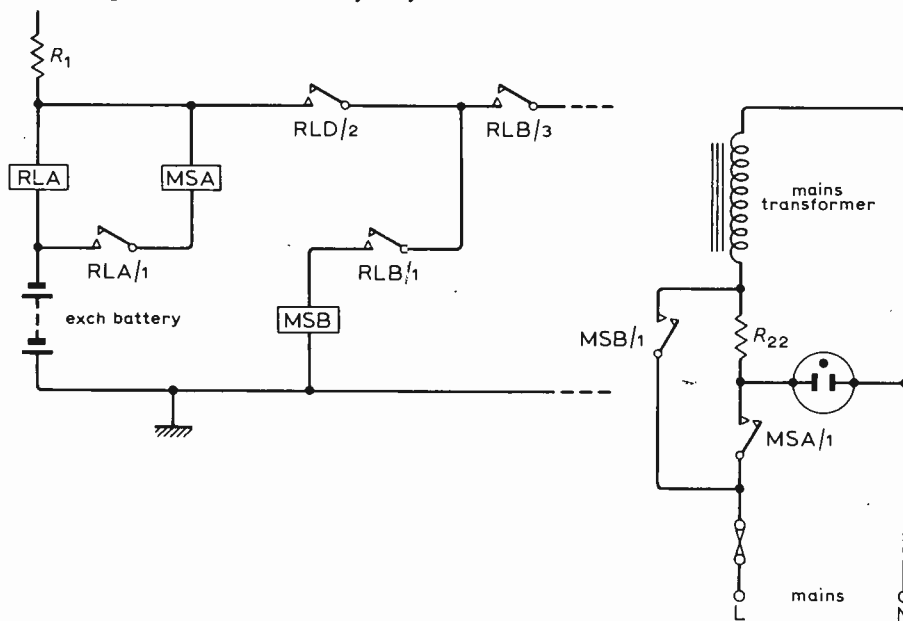

# Electronic Building Bricks

## 21. The closed-loop follower

by James Franklin

In industrial and domestic equipment we sometimes wish to make an output variable automatically 'follow' an input variable — to go through the same pattern of change with time in strict proportionality (i.e. with a constant ratio of output value to input value). To illustrate the idea some examples of followers\* are shown in Fig. 1. In a servomechanism (a), the output variable could be mechanical displacement providing high power (e.g. moving a large load), which is following an input displacement of low power, such as a manually-operated lever. At (b) is an

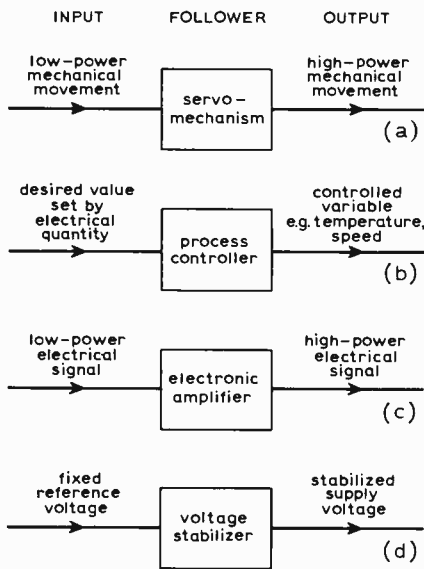

Fig. 1. Examples of followers.

electronic controller as used in industrial process control. Here the output variable 'follows' the input variable in that it stays fixed in a constant ratio to the adjustable electrical input value. If the input variable is re-set, usually by hand, to some new desired value the output variable changes correspondingly and remains constant at the new value. At (c) is an electronic amplifier as used in radio and television: the high power output signal must accurately follow the low power input signal, otherwise distortion of the signal waveshape will occur. Finally at (d) is a

\*Not to be confused with certain electronic circuits with this name, e.g. emitter follower, cathode follower, source follower.

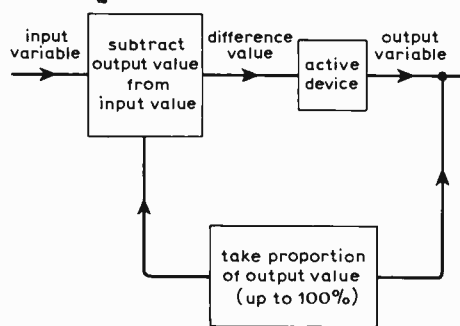

Fig. 2. Basic principle of the closed-loop follower.

voltage stabilizer for the power supply of electronic equipment. This is similar to (b) in that its output variable 'follows' the input variable, a fixed reference voltage, by staying constant at a voltage proportional to that reference voltage.

How can the engineer be certain that the output variable is indeed accurately following the input variable? For example, in an electronic amplifier, as described in Part 9, if there is a non-linear relationship between the power changes in the high-power circuit and the power changes in the low-power circuit the output variable will certainly not follow the input variable — the amplifier will introduce distortion. A basic method adopted to ensure accurate following is shown in Fig. 2. This is to compare continuously the output variable, or a proportion of it, with the input variable, subtract the output value from the input value (see Part 14) and use the difference value as the input to the active device. (By active device we mean a motor, linear actuator, flow valve, electronic amplifier etc. according to the nature of the

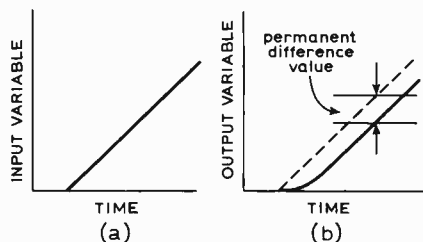

Fig. 3. The permanent difference value required in a closed-loop follower: (a) the input variable and (b) the output variable.

follower.) Consider now what happens if the output variable does not follow the input variable. If for a given increase of the input variable, the output variable increases disproportionately, the magnitude of the fraction sent back to the subtractor is also increased and so the difference value is reduced in magnitude. Since the active device is controlled by the difference value, the magnitude of the output variable is reduced. Thus an automatic correction has taken place. Conversely if the output variable decreases disproportionately for a given input variable decrease, the fraction sent back to the subtractor will also be decreased, the difference value will be increased and the magnitude of the output variable will be increased — again an automatic correction.

It might be thought that the system should operate to make the difference value become zero, since this would show that the output was exactly the same as the input. In fact this cannot be, first because permanent zero input to the active device would mean permanent zero output, which would be useless. Hence a small difference value must always be maintained, and this is illustrated in Fig. 3. The smaller the difference value the more accurate the follower, so to permit an extremely small difference with the required output value the active device must be designed to magnify its input as much as possible. Another reason for the presence of a difference value is that in a practical system, such as an electro-mechanical positioner, information takes

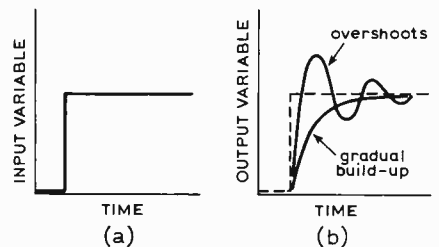

Fig. 4. Two possible transient errors (b) when a closed-loop follower responds to a sudden change in the input variable (a).

time to travel through the active device and back to the subtracting device. Some of this delay could be caused by components which have electrical or mechanical reactance (see Part 7) and this causes a transient error when the follower is responding to a sudden change in the input variable. Two possible examples of this are shown in Fig. 4 (b), one being a gradual build-up of the output variable and the other a series of overshoots.

Because in Fig. 2 information flows from the output back to the input a loop is formed, and the method is known as closed-loop control. It goes under various names in particular apparatus (sometimes depending on what the input and output variables are), such as error-correcting, null-seeking, self-balancing, servomechanism, automatic regulator, phase-locked loop, automatic gain control, automatic frequency control, and negative feedback (the word 'negative' being derived from the subtraction process mentioned above).



# F.M. Tuner Design -- 12 Months Later

by L. Nelson-Jones, F.I.E.R.E.

The author of the articles on the stereo f.m. tuner design (April, May 1971) looks back on the 12 months since the design was published and gives some hints on getting the best from the design. Cures are listed for the small number of troubles – out of nearly 2,000 tuners for which parts have been sold – experienced by readers. Test voltages are also given as well as dial mechanism and stereo decoder mounting details. A solid-state tuning indicator is described separately on pages 182 and 183.

This tuner has been made by many of the readers of *Wireless World* and, inevitably, a few of these tuners have given trouble. Most of these troubles have been traced to component faults, or errors in construction, but two faults in particular have recurred in a number of cases. One of these is concerned with oscillator tracking, and the other an instability, apparently in the r.f. section, but which is very difficult to track down.

### Oscillator tracking

In many cases it has not been possible to get the oscillator to quite reach 108-MHz

coverage while at the same time covering down to 87.5MHz, because the oscillator coil could not be closed up enough without shorting. The first attempt to increase the inductance of the oscillator coil was to reverse the direction of winding thus giving about an extra half turn. This proved to be too big an increase resulting in the coil not being able to be reduced in inductance sufficiently even with the turns highly extended. The next move was to increase the diameter of the coil some 15%, but this too proved non-effective due to the close proximity of the tuning capacitor body, and in

fact an appreciable drop in inductance was noted. Finally it was found that the very small increase in inductance needed could easily be obtained by standing the coil further away from the printed circuit board. Instead of mounting the coil so that the turns are 2.5mm clear of the board, as described in the original article, it should be mounted with 5 to 6-mm clearance. The coil should now track easily with the turns spaced from one another by about half a wire diameter. The r.f. coils both track normally with the turns spaced by approximately one wire diameter. In each case this is about the 'natural' length of the coils.

In existing tuners it will be necessary to remove the oscillator coil and fit a new one to effect this cure as it is unlikely that the existing coil will have sufficient surplus lead length. Take great care when removing the leads from the board. The simplest way in my experience is to cut the coil off leaving a reasonable lead length, and then to remove each lead separately, being very careful to pull the lead through the board from the component side (never from the copper circuit side). This minimizes the risk of 'pad lifting'. The holes are then cleared of solder, being careful not to increase the hole diameters, and a new coil fitted in the normal manner but with the increased clearance. Fig. 1 shows the amended mounting details for the coil.

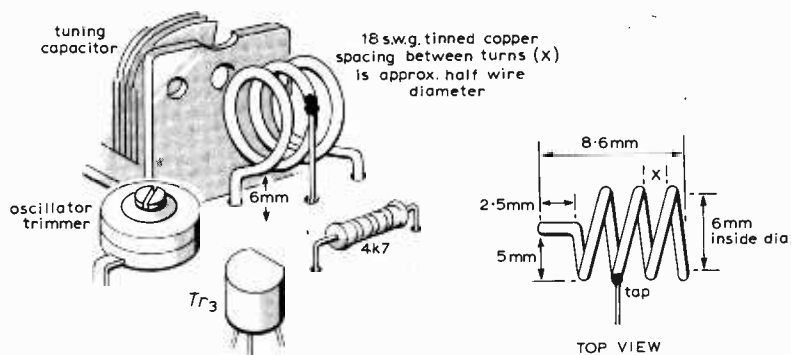

Fig. 1. For those who cannot tune to 108MHz, inductance of oscillator coil can be increased by moving it further away from the printed board.

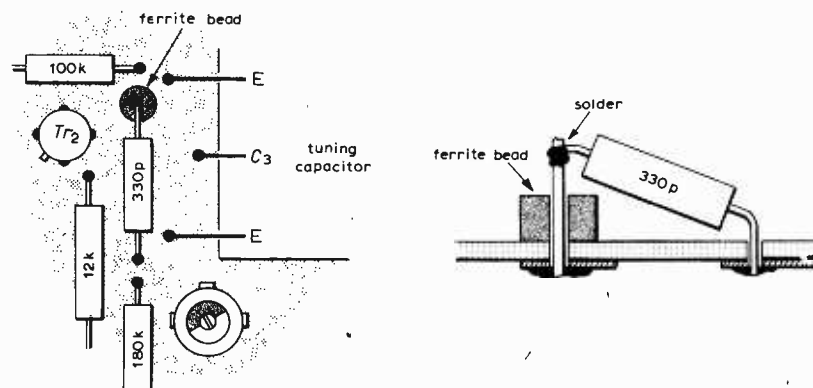

Fig. 2. In some cases unwanted oscillation at around 500MHz has caused odd effects, and has been cured by adding a ferrite bead as shown (see also photograph).

### Instability

This fault has proved a very elusive one which nearly always shows up only at the upper end of the frequency coverage. It can also show up as an excessive noise level, with more than a reasonable number of spurious responses, but with the tuner working quite normally on strong signals. Most readers deduced that the mixer was unstable, others that it was the r.f. stage, and some that the oscillator was squegging, which can give a similar effect. In fact it seems likely that all three stages are involved, as the oscillation is almost certainly not at the normal carrier frequencies for which the receiver was designed but around 500MHz.

It is extremely hard to track down the exact mechanism, but it appears that it is usually associated with f.e.t.s having higher than average gain in this u.h.f. region. An f.e.t. differs from a bipolar device in that the drop off in gain with frequency is much

more sudden. A device such as those used in the tuner r.f. and mixer stages can have barely reduced gain up to say 450MHz, above which the gain rapidly reduces so that little gain exists at say 600MHz. For this reason I believe that only a few tuners have this trouble, and this is confirmed by the fact that of those with the trouble that I have examined, all had f.e.t.s in the r.f. stage with higher than usual  $I_{dss}$  currents, and with these devices one would usually expect a higher gain at u.h.f.

The path for the feedback appears to be via the  $g_2-g_1$  capacitance of the mixer, via the oscillator layout to the r.f. stage input, through this stage back to  $g_1$  of the mixer and thus full circle. This view of the mode of oscillation is backed by a number of facts, such as the fact that the oscillation frequency is unaffected by the receiver tuning, but is affected by the voltage applied to the 'varicap' diode, and that a ferrite bead in series with the oscillator feed to  $g_2$  of the mixer effectively suppresses the oscillation. I suspect that the inductor forming the u.h.f. resonant circuit is formed by the earth plane of the printed board.

The cure for this problem is thus a very simple one and the location of the ferrite bead is shown in Fig. 2. It is mounted on the lead of the 330-pF oscillator feed capacitor. It may be mounted on either end of the capacitor, but is more easily mounted on the end shown. To mount the ferrite bead (Mullard FX1115 or Radiospares anti-parasitic beads) on a tuner already constructed, the end of the capacitor is unsoldered from the board, a tinned copper wire is soldered in place of the capacitor lead in the board, and the ferrite bead placed on this lead. The capacitor is then soldered to the wire above the bead (Fig. 2).

### Oscillator temperature coefficient

A small number of readers have complained of excessive drift of the tuner, even with the a.f.c. switched on. It is suspected that the oscillator may have had a faulty component in these cases, but a tuner subjected to a

*Unwanted oscillation at u.h.f. may be cured with a ferrite bead over the lead of the oscillator output capacitor.*

large change in temperature on warming-up (for instance a tuner in use in the same cabinet as a valve amplifier) may give rise to some problems. The main component causing the drift is the oscillator trimmer capacitor which has a temperature coefficient of up to  $-1000$  p.p.m./deg C. Most of the oscillator components have measurable temperature coefficients, but the trimmer is much the highest.

It must not be forgotten that the tuner must be operated from a stable supply as the tuner has quite a high voltage-versus-frequency coefficient— $330$  kHz/V without a.f.c., and  $60$  kHz/V with.

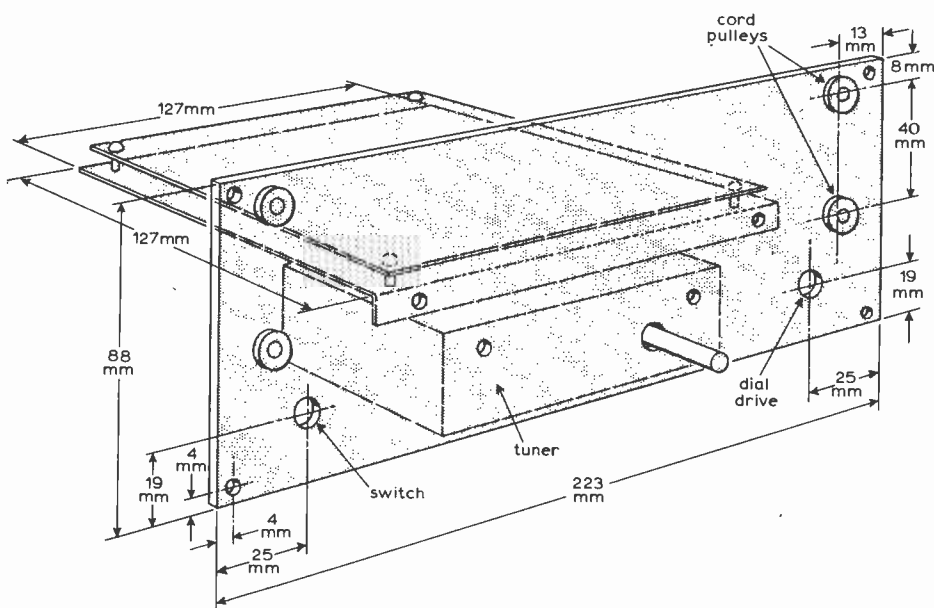
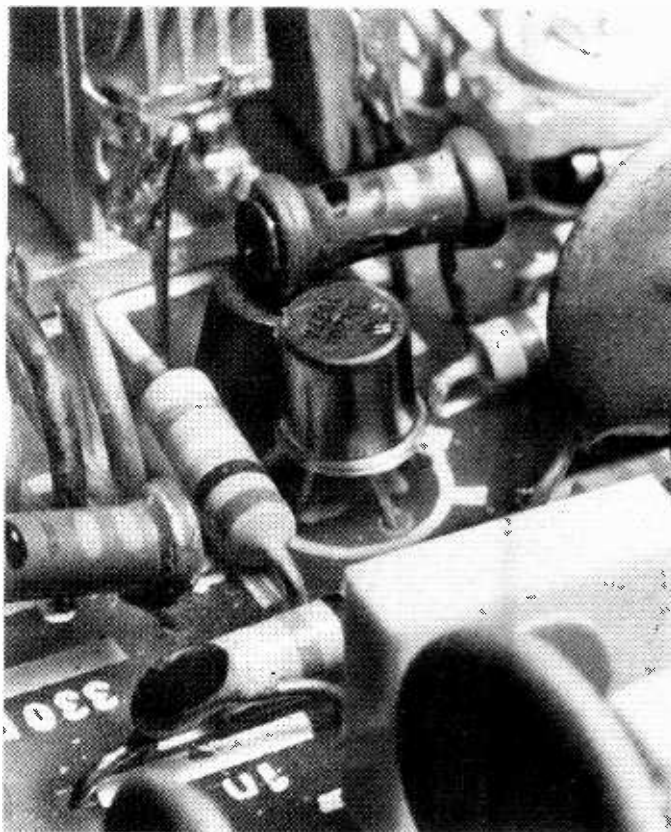

Fig. 3. New dial mounting system applicable when using stereo decoder (a) and front panel cut-outs for tuning meters (b).

Measurements have been made on a tuner fitted with a trimmer having a lower temperature coefficient of N470 (i.e.  $-470$  p.p.m./deg C). This trimmer gives rather better drift figures:  $-6$  kHz/deg C with a.f.c. and  $-16$  kHz/deg C without a.f.c. These figures are quite acceptable in normal circumstances.

Thus for readers having trouble with drift the change to the N470 device, which is of the same type as that used at present but of 3.5 to 13pF range, will make a considerable improvement.

For those requiring a still greater freedom from drift the use of an air dielectric or p.t.f.e. trimmer will give an improvement. Jackson type 5440/PC/PT/14.0 should be adaptable to the task although its pins will need spreading slightly, and the stator and rotor connections will be reversed so that on tuning with a screwdriver the placing of the screwdriver in the slot will pull the oscillator off tune and the screwdriver must be removed before re-checking the alignment.

My advice is therefore to leave well alone unless drift is a problem, in which case an investigation should be made to ascertain the component responsible in case there is a faulty item. Should the trimmer be the cause as indicated then a change to a type having a better temperature coefficient may be the cure. The most useful tool to ascertain approximately the relative temperature coefficients of the various components is a miniature soldering iron, which may be held close to components to heat them up, in conjunction with a tuning meter of approximately 2–0–2V f.s.d. The drift of the tuner is easily seen on such a meter which has a deflection constant of approximately 100kHz/V. A 'freezer' aerosol is not

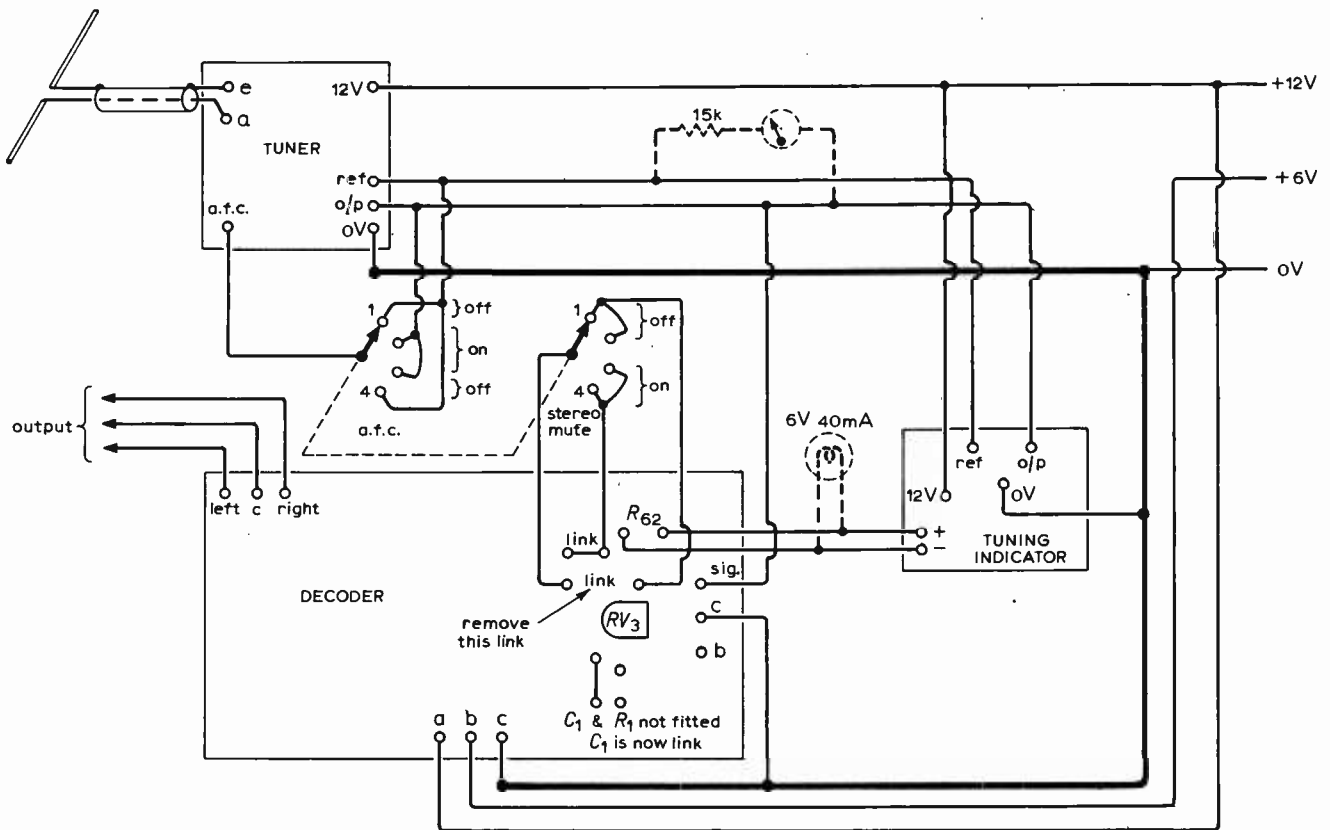

Fig. 4. Wiring diagram for connecting decoder and tuning indicators.

satisfactory as the large amount of condensation produced causes erroneous results due to the effect of the moisture on the stray capacitances.

**Mounting the tuner and decoder**

In the original article I suggested a method of mounting the tuner which is quite satisfactory. However, many readers will want to take advantage of the increasing amount of stereo broadcasting now available, and to receive these transmissions a decoder is needed. The design by Portus and Haywood (September 1970 issue) works well with the tuner, and I have therefore designed a new dial mounting system for use with this decoder and either a moving-coil meter or solid-state tuning meter. This chassis system is shown in Fig. 3.

The interconnection of the tuner and decoder is a simple matter provided the decoder has been assembled for single polarity supplies. Using supplies of +6V and -6V would mean having three separate supplies for tuner and decoder together. The connections are shown in Fig. 4. This also shows the connections needed to mute the decoder in the event of excessive noise on stereo transmissions, thus gaining the 20dB or so extra signal-to-noise ratio of a mono signal. There are two possibilities for muting the decoder, (a) the decoded outputs may be shorted together or (b) the decoder may be disabled by reconnecting the junction of  $R_{46}$  and  $R_{48}$  of the Portus and Haywood decoder to 0V (connection C) instead of to the collector of  $Tr_{13}$ . This point of the circuit is easily accessible and the resistor junction is disconnected from  $Tr_{13}$  by removing a link on the board adjacent to  $RV_3$ , replacing it with two leads

to each end of the previous link. A third lead is connected to the short link adjacent to the positive end of  $D_4$ , and next to the link removed. These connections are shown in Fig. 4.

Either a three- or four-way switch may be used for a.f.c. and decoder muting, depending whether muting is required with or

**Test voltages for f.m. tuner**

test point	voltage relative to 0-V line (V)	comments
$Tr_1$ gate 1	0	
gate 2	4	
source	1	approx. 0.7 to 1.5V spread
drain	11.5	
$Tr_2$ gate 1	0	
gate 2	1.7	approx. 1.0 to 2.0V spread
source	1	approx. 0.7 to 1.5V spread
drain	11.7	
$Tr_3$ emitter	5.4	
base	6	
collector	12	
$Tr_4$ emitter	6.6	
base	6	
collector	0.75	
$IC_1$ pin 1	no connection	
2	3.6	
3	0	
4	2.9	
5	7	
6	9.7	
7	11.5	
8	no connection	
$IC_2$ pin 1	5.8	depends on tuning (4 to 7.5V)
(nominal)		
2	3.5	
3 & 4	0	
5, 6 & 7	1.35	
8	0.13	
9, 10 & 11	0	
12	3.5	
13	11.5	
14	5.2	depends on tuning (3 to 7.5V)
(nominal)		
a.f.c. reference	5.2	

Measurements assume a meter of 20k $\Omega$ /V and a +12-V supply.

without a.f.c. This is the last position of the four-way switch, and is not strictly necessary. However, for completeness the four-way switch is shown.

All parts for this dial system and the stereo decoder mounting are available from Integrex Ltd, P.O. Box 45, Derby, TE1 1TW, including a set of printed scales. The ferrite bead is also available.

Finally, a list of alterations and corrections to the original article, some of which have already been published.

- A capacitance of 15pF is now recommended for the oscillator base capacitor, not 47pF.
- Decoupling of r.f. stage is 1nF, not 47nF (top of  $L_2$ ).
- Fig. 2 caption last line should, of course, read '4.7nF at pin 1 of  $IC_2$ ', not pin 2.
- In Fig. 2, the 2.2k $\Omega$  resistor at pin 5 of  $IC_1$  should go directly to the +12V supply, and not via the 100- $\Omega$  resistor.
- In Fig. 6(c) the coil ( $L_5$ ) should have 10 turns.
- The components list should have listed 1nF, nine off, and 47nF, nine off, disc ceramic capacitors.
- Type 3N201 m.o.s.f.e.t. can be used in place of the 40673.
- Texas types TI409 or TIS64 can be used in place of the 40244 transistor, now obsolete.
- Ferranti transistor type ZTX500 can be used in place of BC213L.
- ITT diode type BA110 can be used in place of TIV307.

Turn over for notes on tuning indicators.

# Fitting a moving-coil or solid-state tuning indicator

Fitting a tuning indicator to the f.m. tuner is a simple matter using a centre-zero meter of 100-0-100µA sensitivity (Fig. 1). With a correctly-aligned tuner the d.c. output level and a.f.c. reference voltages are equal when the tuner is on tune, and differ when it is off tune. Thus as a station is tuned in the meter first deflects to one side as the station is reached, then deflects back through zero as the station's frequency is passed, finally falling back close to zero when well off tune again. If a.f.c. is switched on the above effect is modified. On tuning towards a station the meter suddenly snaps to a reading as the a.f.c. captures the carrier. This reading may be either side of zero depending on how fast one tunes to the station. It is then only necessary to set the meter to zero for correct tuning, as the tuning cannot remain on any section of the S-shaped demodulator characteristic except the correct central portion, due to a.f.c. action. On tuning off the station with a.f.c. connected, the meter will deflect to a maximum in the appropriate direction and then snap near to zero as the a.f.c. 'loses' the station.

In designing the tuner I deliberately did not use a very strong a.f.c. control loop so that tuning could be done with or without a.f.c. In normal use it is often easiest to leave the a.f.c. permanently on, as tuning with moderate a.f.c. is so simple, especially for the less-skilled members of the family.

The cut-out for the dial panel is shown in Fig. 2.

## Solid-state indicator

The recent improvement in the availability of light-emitting diodes at acceptable prices makes their use for indicators in electronic equipment very attractive. Fig. 3 shows a simple circuit using these diodes. Correct tuning (i.e. equality of output and a.f.c. reference voltages), is indicated by equality of the light output from the diodes  $D_1$  and  $D_2$ . The diode  $D_3$  and its associated resistors are for use as a stereo indicator lamp. The values chosen produce the approximate equivalent of a 6-V 40-mA lamp, and were chosen to match the requirements of the stereo decoder by Portus and Haywood (September 1970 issue).

The action of the circuit of Fig. 3 needs little explanation. It is a long-tailed pair which with equal voltages at the two bases will pass equal currents through the two diodes. When the base voltages differ the current through the long-tail resistor divides unequally between the two transistors, so that when the input to  $Tr_1$  is approximately 1V below the input to  $Tr_2$  then most of the current flows through  $Tr_2$  and  $D_2$ . When the input to  $Tr_1$  is approximately 1V above the input to  $Tr_2$  then most of the current flows through  $Tr_1$  and  $D_1$ .

Fig. 4 shows the relationship between the potential difference of the bases of  $Tr_1$  and  $Tr_2$  and the current through the two diodes as measured in the circuit of Fig. 3. The difference in peak currents off tune is of no practical importance as the visual difference

is not great, and in any case there is no basis for comparison as either one light is on, or the other. In use the correct tuning point is easily found. Because the input impedance loads the output of the tuner, it is important to ensure that the input impedance of this tuning indicator is sufficiently high and linear, over a range of

approximately  $\pm 1V$  about the centre. Full  $\pm 75\text{-kHz}$  deviation is equivalent at the tuner output to  $\pm 0.7V$ . This requirement for reasonable input impedance linearity has been achieved in this circuit by degeneration in the emitters of  $Tr_1$  and  $Tr_2$ , the resistor values being chosen to obtain the correct sensitivity.

The input resistance of the circuit is

$$\beta_1 \left[ r_{e1} + R_2 + \frac{(R_4 + r_{e2} + R_5/\beta_2)R_3}{R_4 + r_{e2} + R_5/\beta_2 + R_3} \right] + R_1$$

Assuming minimum current gain for the

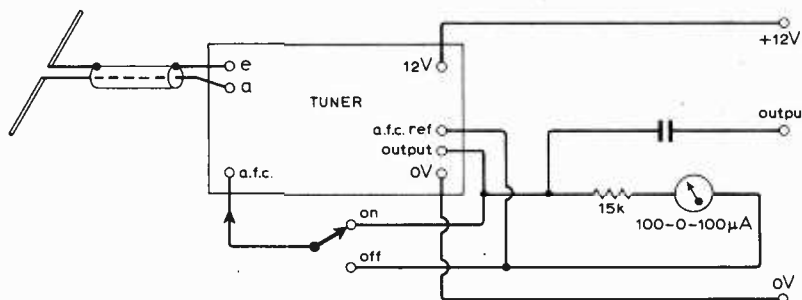

Fig. 1. Adding a moving-coil indicator is simple. With a.f.c. on and with a station tuned in, one merely sets the meter for zero indication.

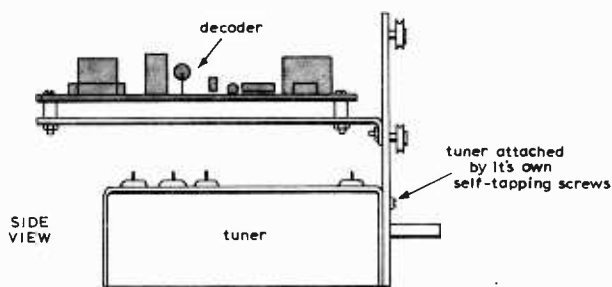
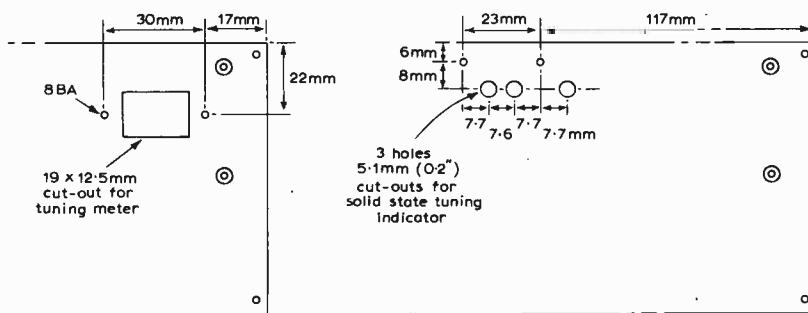

Fig. 2. Cut-outs for the two alternative tuning indicators.

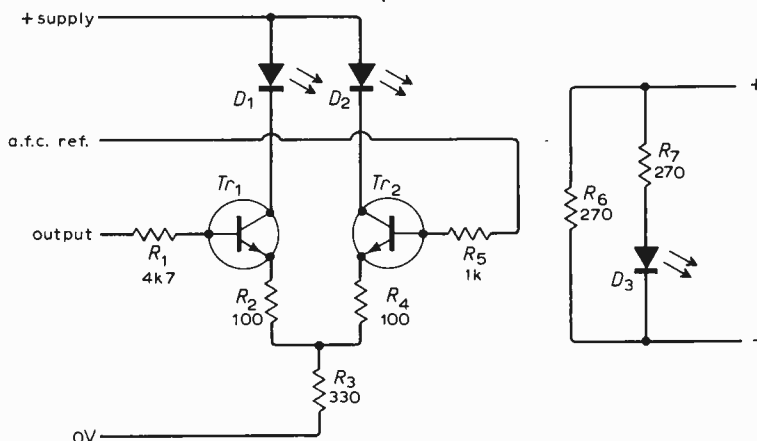
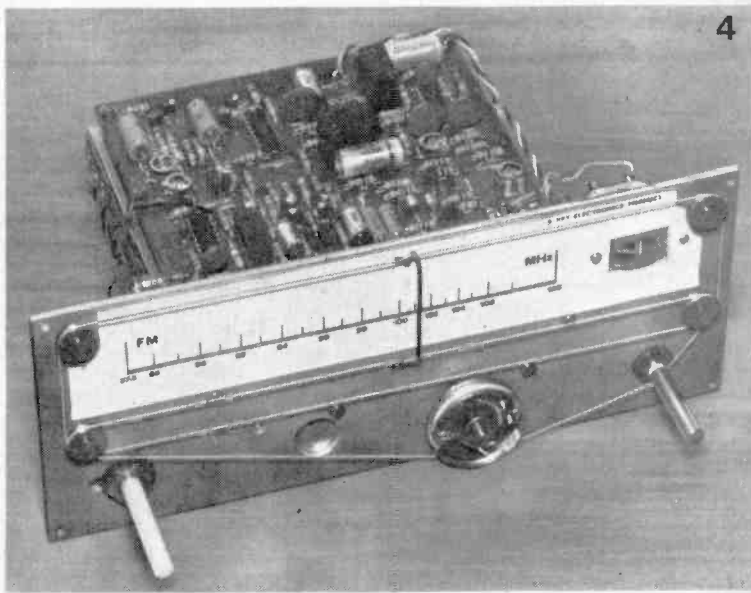
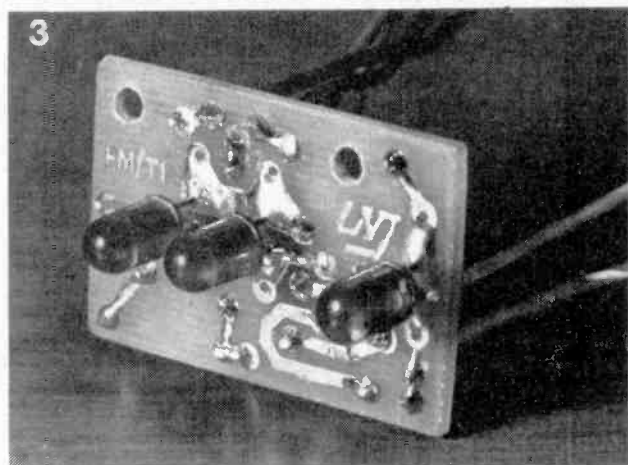
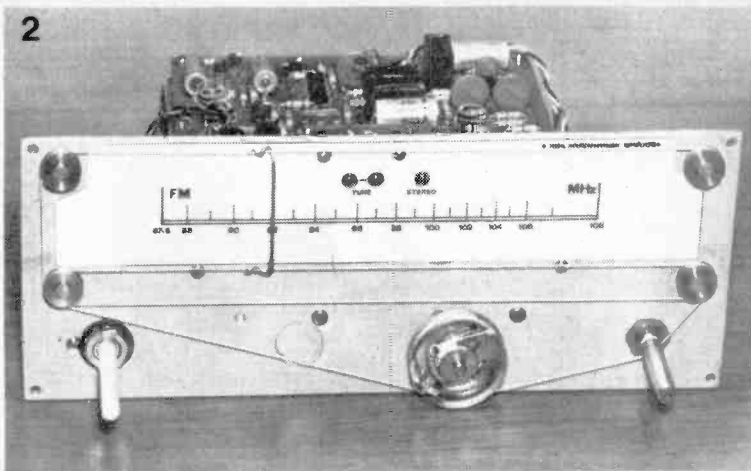
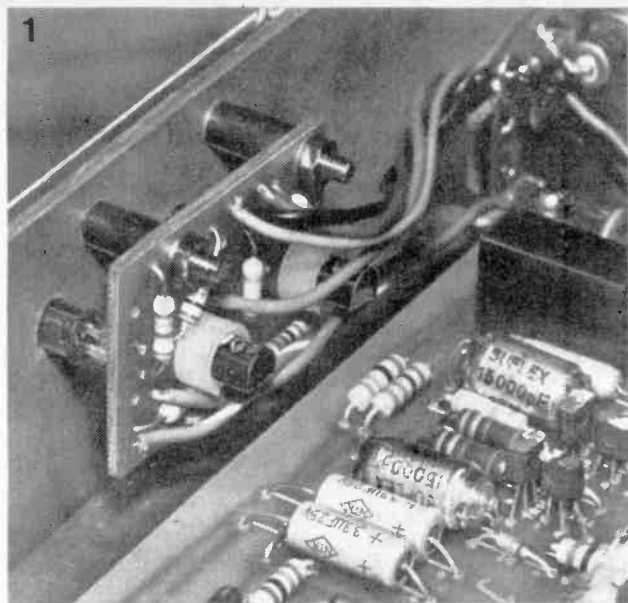

Fig. 3. Author's suggested circuit for solid-state indicator gives both tuning and stereo indication. Diode cathode is identified by the short lead and orange spot.



1 and 2: Mounting of solid-state indicator p.c. board. 3: Diodes mounted on p.c. board. 4: Front panel with moving-coil indicator.

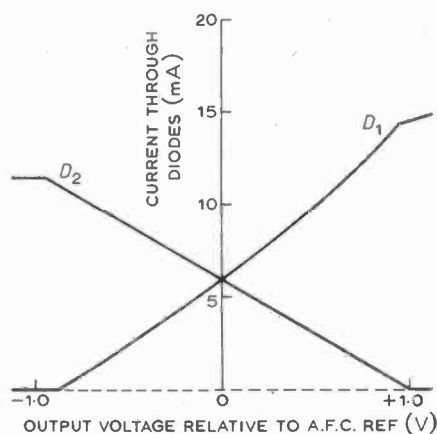

Fig. 4. Difference in off-tune current between the two diodes is not important as the lamps are never both fully on.

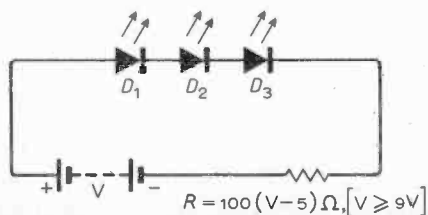

Fig. 5. The two diodes with most nearly equal brilliance can be selected for the tuning indicator when operated in series.

transistors of 220 and the values of Fig. 3 we get values of  $47.35k\Omega$  for  $V_{in}$  0.7V above a.f.c. reference, and  $46.50k\Omega$  for  $V_{in}$  0.7V below. The attenuation ratio formed by the output impedance of the tuner ( $2.2k\Omega$ ) and the tuning indicator circuit therefore varies by less than 0.08% over this span. Even if it were not for the need to linearize and raise the input impedance of the tuning indicator,  $R_2$  and  $R_4$  would still be needed, because with these two resistors effectively removed (by connecting together the two emitters of  $Tr_1$  and  $Tr_2$ ), the complete span from  $D_1$  full on to  $D_2$  full on is only  $\pm 0.2V$ . This sensitivity is too high for easy tuning and considerable flicker of the diodes is caused by the modulation of the carrier.

The resistors  $R_1$  and  $R_5$  are chosen to equalize the resistance seen by the two transistors, to minimize offset due to base current. These base resistors also ensure that the circuit does not become a resonant line oscillator when long leads are connected to the circuit. With modern planar transistors it is all too easy to get such effects if precautions are not taken.

**Construction**

The prototype tuning indicator is shown above, with the board mounted behind the tuning dial of a tuner. (A photograph shows the unit removed from the dial to show the

mounting of the diodes.) The board is designed to take the type of diode having two pins on 2.5mm (0.1in) centres, and these are mounted on the circuit side. If desired, the board can be mounted remote from the diodes with leads from the board to the diodes.

**Lamp matching.** As there is some variation of brilliance of the diodes with identical currents from one lamp to another, it is desirable that the two lamps  $D_1$  and  $D_2$  be approximately matched for brilliance. This is easily done by temporarily connecting the lamps in series and passing a current through all three lamps at once (Fig. 5). The two lamps having most nearly equal brilliance are used for  $D_1$  and  $D_2$ .

Avoid excessive heat or mechanical force on the leads of these lamps as they are easily damaged by heat, by the nature of the materials used and of their small size.

**Components.** Resistors should be  $\frac{1}{8}$ -watt, 5% tolerance and of the carbon film type. Transistors should have a  $V_{cb} \geq 20V$  and an  $h_{FE} \geq 220$  at  $I_C$  of 5mA, e.g. BC109, BC169, BC184L. Diodes are Hewlett Packard 5082-4440. All parts for the tuner, decoder, and indicator are available from Integrex Ltd, P.O. Box 45, Derby, DE1 1TW.

# About People

'For his outstanding contributions to electronic engineering, particularly in the development of microwave radar, and for his contributions to engineering education and training', the I.E.E. has elected **G. S. C. Lucas**, O.B.E., Hon.D.Tech., F.C.G.I., an honorary fellow. Mr. Lucas retired from A.E.I. Electronics, of which he was director and group general manager, in 1966. He started his career with the British Thomson-Houston Company in 1915 and after serving his apprenticeship studied at the City and Guilds (Engineering) College, London. In 1925 he went into the B.T.-H. research laboratory where he became responsible for developments in the audio engineering field. For his contribution to the development during the war of centimetric fire-control radar Mr. Lucas was awarded an O.B.E. When, in 1945, the B.T.-H. Electronics Engineering Dept. was set up he became manager and in 1952 chief engineer.

The fiftieth award by the I.E.E. of the Faraday Medal has been made to **Professor F. C. Williams**, C.B.E., D.Sc., D.Phil., F.R.S. 'for his outstanding contributions to the theory and design of electronic circuits; his leadership of the team which developed the best computers to be sold commercially; his contributions to the theory of alternating-current motors; and his leadership of the team which made important contributions to the design of electric motors and generators'. Professor Williams, who is 60, was a member of Watson-Watt's radar research team at Bawdsey from 1939. In recognition of his work on the development of I.F.F. (identification, friend or foe) he received the American John Scott award. In 1947 Dr Williams joined the staff of Manchester University where he is professor of electrical engineering.

**Douglas Stevenson**, aged 45, assistant general manager of ITT Components Group Europe for the past two years, has been appointed general manager of the Group.

Educated in Edinburgh, Mr. Stevenson joined Standard Telephones and Cables Ltd, a subsidiary of ITT, in 1955, later becoming manager of ITT's Capacitor Division at Paignton. In 1961 he moved to Brussels as manager of the Components Division of ITT Standard. Returning to the U.K. in 1963, he became manager of the then Components Marketing Division of S.T.C. at Footscray, Kent. At the beginning of 1970 he became assistant general manager of the Brussels-based ITT Components Group Europe with factories in Germany, the U.K., France, Portugal, Switzerland, Italy and Spain.

**R. B. Coulson**, B.E., B.Sc., M.I.E.E., has been elected to the board of the English Electric Valve Co. and appointed general manager. Born in Australia, and a graduate of the University of Sydney, Mr Coulson came to England in 1949, and joined E.E.V. in 1950 taking charge of the development and production of travelling-wave tubes. In 1958 he was promoted sales manager. E.E.V. has also announced the appointment of **F. C. Thompson**, B.Sc., Ph.D., F.I.E.E., as deputy general manager. Dr. Thompson graduated from Liverpool University, and served with A.A. Command before becoming a senior scientific officer at the Telecommunications Research Establishment, Malvern, in 1942. He joined E.E.V. in 1945 as engineer in charge of microwave tubes, and was made manager of the Radar Tube Division in 1956. He was appointed assistant general manager in 1962, and elected to the board in 1969.

**Ivan J. P. James**, B.Sc., F.I.E.E., F.I.E.R.E., who has been with EMI since 1937, has been appointed scientific adviser to the company's Central Research Laboratories while still retaining his present position of technical director of EMI's Sound and Vision Equipment Division. Mr. James led the team which designed the 2001 colour television camera.

EMI have also announced the appointment of two assistant directors in the Central Research Laboratories. They are **J. A. Lodge**, who has become assistant director, audio and television research, and **R. J. Froggatt**, assistant director, systems research. Mr. Lodge assumes responsibility for work in audio frequency techniques, mechanics and optics, sound recording and reproduction, and television. Mr. Froggatt takes charge of research on all other systems including cognitive, display and microwave systems, and automation.

**Michael Moore**, M.I.E.R.E., is appointed technical manager responsible for design and development and the manufacturing activity of the electronics division of Benney-Geartech Ltd., of Chandler's Ford, Hants. Mr. Moore has spent the last six years as a senior engineer with C.E.R.N., the European organization for nuclear research.

**Bert Horlock**, M.I.E.E., M.I.E.R.E., chief engineer of Granada TV Rental has been appointed to the board of the company. He joined the Granada organization in 1961 at the Manchester TV Centre and in 1965 transferred to the television rental company as chief engineer responsible for research and development and also technical training and standards.

**Cyril G. T. Withers**, chief experimental radio officer at the Aeroplane and Armament Research Establishment, Boscombe Down, retires on the 31st March, after nearly 26 years service in the Navigation and Radio Division. Mr. Withers joined the Air Ministry Research Establishment (later T.R.E.) in 1940 and worked on the development and the operation of the C.H.L. and G.C.I. radar systems. For part of this period he was attached to R.A.F. 60 Group, Leighton Buzzard. In 1943 he was granted an honorary commission in the R.A.F. for special ground and airborne radar duties overseas. At the end of the war he was attached to 'T' Force in Germany which was formed to investigate the activities and progress of German scientists. He was later transferred to A. & A.E.E. to take over the Airborne Radar Trials Section. In 1960 he was appointed head of the radio side of the Division from which he is now retiring.

**Richard J. Constantine** has joined Farnell Instruments Ltd. as internal sales engineer at the Wetherby Office of the company. He was formerly a radio and electronics officer with I.T.T. Marine Radio Co. Ltd. He was radio officer on the last commercial trip of the *Queen*

*Elizabeth* and spent some time on the Royal Research Ship *Discovery* where he also started transmitting as one of the few Maritime Mobile amateurs (call sign G3UGF/MM). Farnell Instruments Ltd have their own amateur radio society which uses the call sign G4ADQ.

**M. J. Tattam** has joined GEC-Elliott Process Automation Ltd as sales manager of its Telemetry Systems Division at New Parks, Leicester. He was export manager of the Industrial Instrument Division of Smith's Industries Ltd from 1969 having previously been sales manager, telemetry and data acquisition systems of the instrument division.

**Roger Appleton**, who was named chief engineer (designate) of London Weekend Television last September, when **Brian Pover**, controller of engineering, left the company, has been appointed chief engineer. Mr. Appleton, who was London Weekend Television's head of production engineering prior to his new appointment, began his career in television in 1954, when he joined the B.B.C. In 1958, after a spell at Granada Television, he went to Rediffusion. When London Weekend took over Wembley Studios from Rediffusion in 1968, Mr. Appleton became supervisory engineer. In February 1970 he was appointed head of production engineering responsible for the technical staff and facilities at Wembley Studios. As L.W.T.'s chief engineer, Mr. Appleton is responsible for the installation of technical facilities at its new South Bank Television Centre, which is expected to come into service in April. Mr. Pover, who is being retained by L.W.T. as a consultant, has joined Prowest Ltd, manufacturers of television monitors and other professional equipment, as managing director.

Plessey Telecommunications has appointed **T. H. Pritchard** as manufacturing executive. Major Systems Division; **R. C. Lawson** as general manufacturing manager; and **A. E. Brothers** as manufacturing manager. Mr. Pritchard, who will be at the company's headquarters in Liverpool, joined the Plessey Company at Swindon in 1952 as a quality manager, later becoming divisional manager. Since 1962 he has been responsible for the Garrard manufacturing operation. Mr. Lawson, general manufacturing manager, Strowger Major Systems Division, who is 51, was educated at the Royal Naval College, Dartmouth, joining the Plessey Company in 1946 as a production operator. Mr. Brothers, manufacturing manager at the Company's Edge Lane, Liverpool, factory is also 51, and was previously manufacturing manager at the Plessey installation in Brazil.



# Circuit Ideas

## Active zener with slow run up

The active zener circuit ('High-performance Low-cost "Active Zener" Regulators', Joachim Preis, Oct, 1969) can be combined with the slow run up circuit of P. Lacey (*Circuit Ideas* May 1971) with one transistor doing both functions.

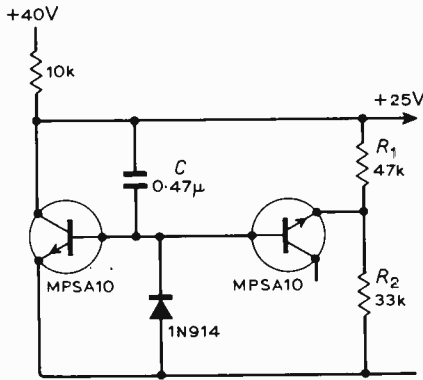

The active zener can operate with very low current, provided that  $R_1$  and  $R_2$  are large and the load current is low. This makes it possible to use a low, non-electrolytic capacitor as the timing capacitor C.  
J. Skjelstad,  
Norway.

## Low distortion f.m. demodulator

A t.t.l. one-shot monostable may be used as a high-linearity f.m. demodulator by connecting it in the circuit shown. Due to

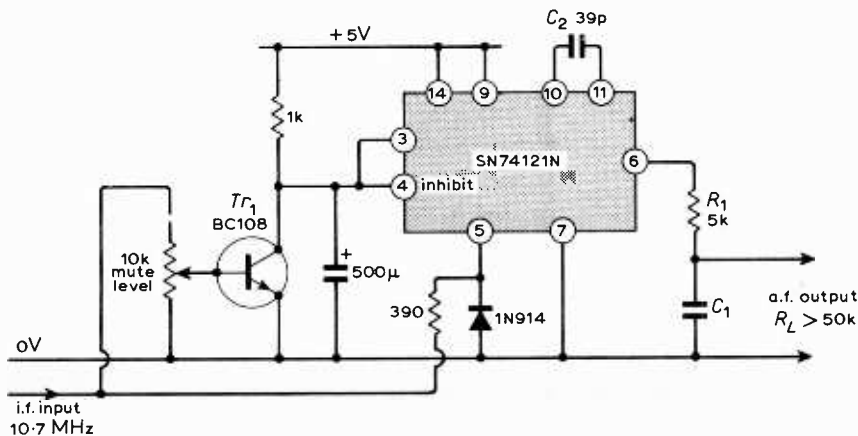

the constant width of the output pulse the duty cycle, and hence the voltage at the output of the integrator network  $R_1C_1$ , are directly proportional to the i.f. Capacitor  $C_2$  is chosen to give a pulse width of 47ns, (the period of one half-cycle at 10.7MHz), this value giving optimum linearity, and as the i.c. includes a Schmitt trigger on the input the circuit need not be driven from a limiter. A demodulator of this type produces high-level noise output in the absence of a proper signal due to random triggering of the one-shot by noise and thus a mute circuit is mandatory. Muting is achieved here by feeding the inhibit terminals of the Schmitt trigger from the collector of the half-wave rectifier stage  $Tr_1$ .  $R_1$  and  $C_1$  also serve as de-emphasis components and therefore the load impedance should be kept as large as possible in order to avoid degradation of the frequency response. Harmonic distortion at  $\pm 75$ kHz deviation is less than 0.5%.

P. Keenan,  
Dunstable,  
Beds.

## Zero marking of a.c. waveforms

It was found that in certain conditions the current of a simple experimental d.c. motor could be negative for part of a revolution. It was easy to show this using a c.r.o. which had a d.c. amplifier — if a double-beam c.r.o. is available, one trace

can be used to indicate zero level. However, when conditions for negative current were being investigated, it was more convenient to mark the waveform of armature current to show the points at which it passed through zero. This could be done by using two diodes as shown in Fig. 1. Current through  $R_1$ , a low-value resistor, develops a voltage proportional to the armature current. Because of the voltage drop across a conducting diode, the relation between the voltage applied to  $Y_1$  and that applied to  $Y_2$  is as shown in Fig. 2. If the voltage under examination becomes very large in relation to the voltage drop across a conducting diode, the 'flats' tend to disappear. If the voltage is less, at positive or negative maxima,

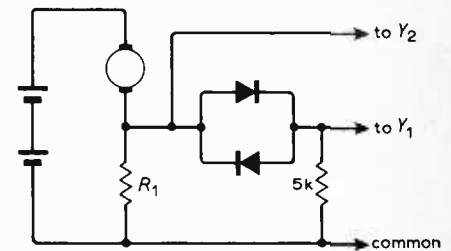

Fig. 1.

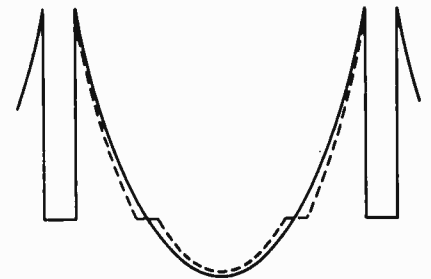

Fig. 2.

than the forward diode voltage drop, the output is zero for the respective period. It should be possible to choose  $R_1$  so that it lies between the two limits corresponding to these conditions.

T. Palmer,  
Kew.

## Constant-current battery charger

The circuit consists of a rectified and smoothed d.c. supply of about 20V, which is applied in series with a constant-current regulator to the battery. The current is derived from switched resistors,  $R_1$  to  $R_5$ , held at a constant voltage by the zener diode and transistors  $Tr_1$  and  $Tr_2$  which form a Darlington pair. Germanium power transistors such as OC28, OC35, OC36, 2N1021, or similar types are used.

The unit which is used for charging batteries up to 12V has several advantages over conventional battery chargers in that the output terminals may be accidentally short-circuited without damage to components. Also, an ammeter is not necessary, since the current is determined by the selection of switched resistors,

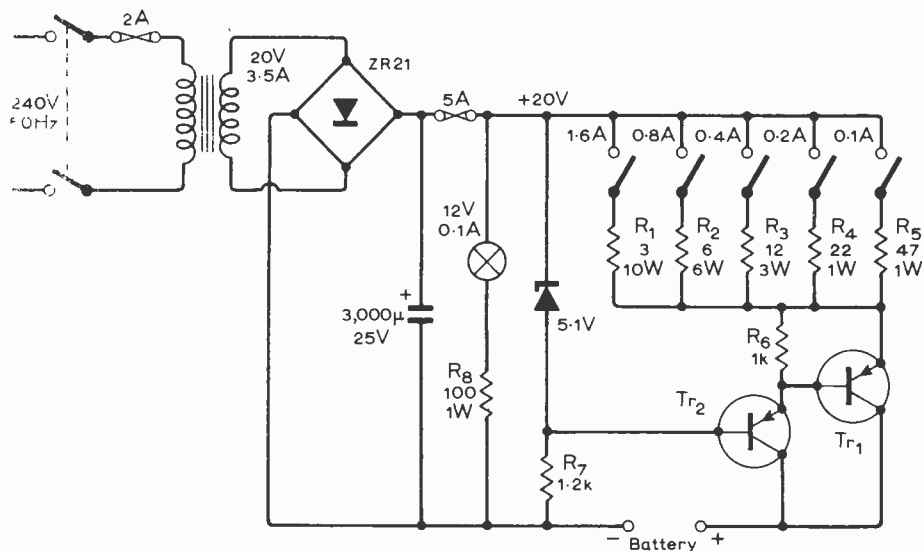

... calibrated current which does not alter during charging. Currents from 0.1 to 3.1A may be selected by closing the appropriate switches and the value of current supplied is approximately given, by  $4.8/R$ , where  $R$  is the appropriate switched resistor. The charging current may be increased to 10A by uprating the components and selecting different values of  $R$ .  
David Allen,  
Manchester.

Now refer to the table below and calculate  $C_1$ ,  $C_2$  and  $C_3$  by multiplying the appropriate factor by  $C_0$ :

For	$C_1$	$C_2$	$C_3$
Multiply $C_0$ by	2.06	0.29	1.03

The capacitors are chosen to be within 1% of these calculated values.

This circuit allows the possibility of using several stages in cascade without emitter following: a 7th order circuit works very well at about 70dB/octave, but different multiplying factors must be considered.

A high-pass filter of the same order can be designed by inverting the elements  $R$  and  $C$  in each stage.

S. J. Morris,  
University Hospital of Wales,  
Cardiff.

### Low-pass active filter

This circuit utilizes a unity gain amplifier configuration, which is stable using a minimum number of components. A wide range of transistors can be used for this amplifier, but low-noise devices are preferable (e.g. 2N2926 for the n-p-n and 2N5354 for the p-n-p). A gain of unity is obtained by choosing  $R_1$  so that  $R_1 = h_{ie} \beta_2$ . Resistor  $R_E$  was chosen to be  $2.7k\Omega$ .  $V_S(+)$  was 10V and  $V_S(-)$  was 15V for the correct d.c. conditions for the transistors.

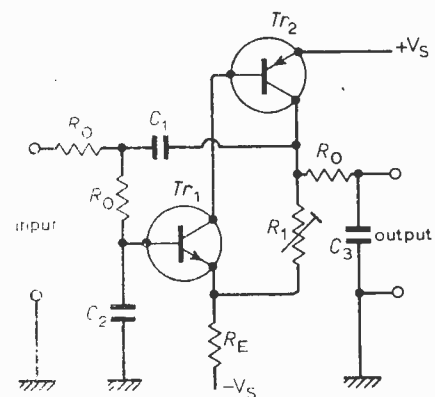

For a ripple of 0.1dB in the pass band and a fall off of 20dB/octave after cut-off frequency  $f_0$ , choose a convenient value of  $R$  and calculate.

$$C_0 = \frac{1}{2\pi f_0 R_0}$$

### Variable-gain volume control

Large overload capability is not often provided by commercial amplifiers, but can easily be obtained by using a variable-gain volume-control stage at the input of the pre-amplifier. Inverting

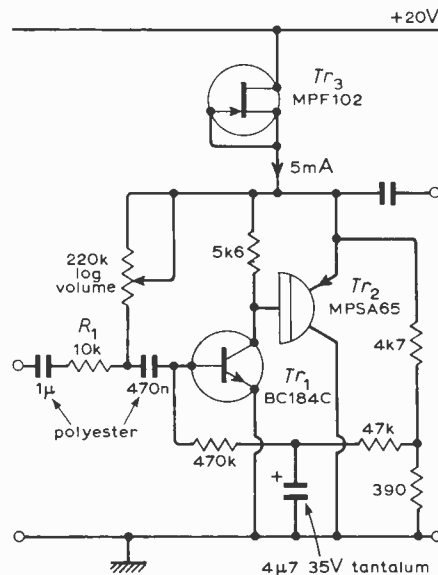

amplifier circuits can easily be designed which will give overload factors of greater than 40dB at normal listening levels. The circuit shown has a maximum voltage gain of  $\times 22$  but this is reduced to nearly zero at the minimum setting of the potentiometer. Sensitivity may be altered by increasing the value of  $R_1$  — e.g.  $22k\Omega$  gives a gain of  $\times 10$ . The inverting amplifier basically has one stage which provides a high open-loop gain ( $\approx \times 2000$ ) by employing a d.c. bootstrap circuit, and applied negative feedback reduces stage distortion to a very low level. Signal-to-noise ratio for the circuit shown is greater than 73dB on a 10mV input. For low noise and distortion the BC184C should be selected to have a current gain of greater than 400, and the field effect transistor (MPF102) should have an  $IDSS$  of 5mA or greater. The circuit is tolerant of hum and noise on the supply line and so may be run from a poorly stabilized supply. Total harmonic distortion at a gain of  $\times 22$  and 1V r.m.s. output measured 0.025% at 1kHz and 0.05% at 10kHz. Equivalent input noise is less than  $2\mu V$ , in the bandwidth 20kHz with input shorted to earth; and upper break frequency ( $-3dB$ ) above 100kHz, with gain  $\times 22$ .

A. Jenkins,  
Taunton.

(The symbol shown for  $Tr_2$ —the Motorola Darlington transistor type MPSA65 — was originally suggested by J. L. Linsley Hood in his article 'The Liniac', published in *Wireless World* in September 1971. Ed.)

### Overtone oscillator

The circuit works well with low activity crystals and is suited to either overtone or fundamental operation. The ratio of the series capacitors controls the amount

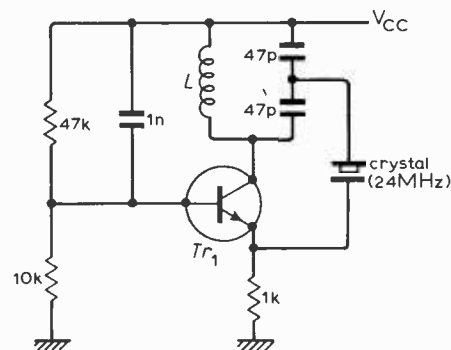

of feedback and the inductor,  $L$ , resonates with the series capacitors at the desired output frequency, giving an output which may be taken directly from the emitter resistor or by means of link coupling. The transistor  $Tr_1$  is a 2N706 (or similar type) and the circuit operates from a 12V supply.  
L. V. Gibbs,  
Wellington,  
New Zealand.

# A survey of Stereo Cassette Tape Decks

## 2: More test reports, a listening test and advice on getting the best from a cassette

by Brian Crank\*

Last month, in part one of this article, we described in detail how the various measurements were carried out and the reader is advised to read this account before interpreting the test results given here. Briefly, we made a set of curves using standard (ferrous oxide) tape on each recorder and, if the machine was equipped with a chromium dioxide tape equalization switch, we repeated the measurements using chromium dioxide tape.

In every case the top amplitude/frequency curve is the left channel at OVU (full recording level). The next two curves below this are the left and right channels at  $-10\text{VU}$  (for assessing channel, balance etc.) and the lowest curve is crosstalk relative to the top OVU curve.

A constant 3kHz signal was recorded on the tape and played back through a spectrum analyser. The results are given in the curves mounted below the amplitude/frequency curves. The major peak is the 3kHz fundamental. The spectrum analyser automatically switched ranges at 6.3kHz so the gap in the response at this point occurs just before the second harmonic. The major harmonic distortion occurs at the third harmonic (9kHz) and is the peak on the right of each trace.

All the measurements given in the test reports are as measured by us. The harmonic distortion figure is high because it includes everything (hum, tape noise etc.) outside a narrow band centred on 1kHz.

### National R-275-U

**Total harmonic distortion 2%: Signal-to-noise ratio, NFD out 44dB, NFD in 50dB: Wow and flutter 0.22%: Bias oscillator frequency 106kHz: Input for OVU, phono L-27mV R-28mV, DIN L-1.6mV R-1.65mV, microphone (not measured): Output DIN and phono L-740mV R-860mV: Rewind 1m 42s: Dimensions 440 × 300 × 120mm. Price £139.95.**

Six oblong push buttons switching internal solenoids are used to control the tape transport mechanism in this machine. This method is convenient, easy to operate and the best we have tested. It is a pity that the wow and flutter is so high. There is a small red light which lights up when the tape is travelling at  $1\frac{7}{8}$  i.p.s. during play and record. In addition when the white record button is pressed the button lights up but the tape does not move until the play button is pressed to give the user a chance to set the recording level. If at the start of a recording, even in the middle of the tape, the tape position counter is set to zero and a switch marked memory is set to on, then at the end of the recording if the rewind button is pressed, the tape will rewind to the start of the recording and switch off automatically.

The machine has twin rotary type recording level controls which make fading a stereo signal a difficult task. The top control panel of the machine is unnecessarily cluttered with a pair of rotary output level controls. When it is considered that the machine will be used in conjunction with a high-quality amplifier incorporating a volume control it makes sense to use preset output level controls on the recorder tucked away at the back of the machine out of sight and out of the way.

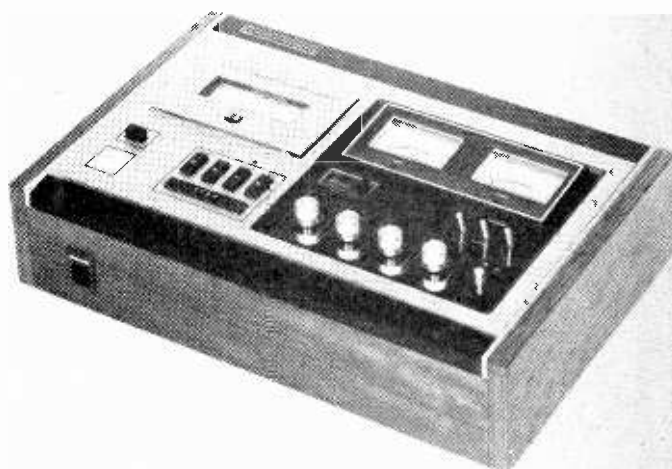

National R-275-U

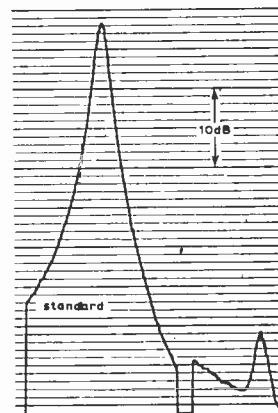
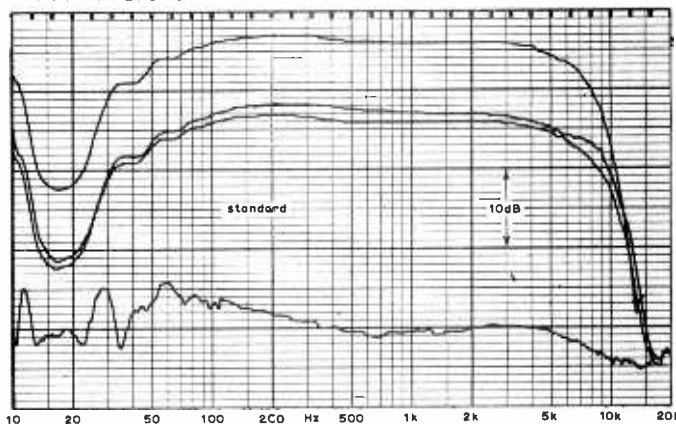

\* Deputy Editor, *Wireless World*

Three toggle switches are used to switch on the memory system, to alter the equalization between 'SG' (special grade?) and normal, and to switch the NFD (noise free device) in and out. We are not sure what is meant by special grade and normal tape but gather that SG out to be used when recording on low noise tape. The machine we tested was not built for the British market and we understand that this switch will be used for conventional chrome/standard equalization switching when the machine is introduced into this country. The NFD was discussed in part 1 in the section on noise reduction systems but it does not compare favourably with the Dolby system. The control panel is completed by an on/off switch and a cassette eject button. A headphone output socket is fitted to the front of the machine.

On the rear of the machine, set in a recess, are the DIN and phono input/output sockets, twin miniature microphone input jacks and a socket for controlling the machine remotely.

We cannot comment on the instruction book, it was written in Japanese! (not being intended for this country).

The sample of the National R-275-U we tested, judged on our measurements, did not compare well with the other machines.

### Sansui SC-700

**Total harmonic distortion 1.6%: Signal-to-noise ratio, Dolby out 47dB, Dolby in 52dB: Wow and flutter 0.14%: Bias oscillator frequency 106.7kHz: CrO<sub>2</sub> erase 52dB: Input for OVU, phono L-66mV, DIN L-14mV, microphone L-0.5mV, centre -0.5mV: Output, phono high L-0.95V, phono low L-300mV, DIN L-0.95V: Rewind 2m: Dimensions 385 × 255 × 103mm: Price £191.65.**

This is another product of Nakamichi Research (look at the frequency response); however, it is somewhat different from the other Nakamichi machines tested in styling and in the facilities it offers. The tape transport is standard and the usual indicator lamp is provided for record. Unfortunately an output level control (dual concentric) is provided on the top control panel. This should have been banished to the back of the machine and the space occupied by a mono/stereo switch which the machine lacks. The recording level controls are also of the rotary dual-concentric type and the friction between the two knobs is such that, once the balance has been set both knobs turn together. This system is quite acceptable. A third rotary level control is used for the centre microphone. This machine is the only one tested which can be used with three microphones simultaneously. The effect of using three microphones, according to the instruction manual, is to 'prevent the shortage of centre sound when recording in a large room with the normal left and right microphones widely separated and to enhance the sound effect in vocal recordings'. The three microphone jacks share the front of the machine with a headphone output jack. Three push-buttons on the top of the machine are used for switching in the Dolby system (with an associated indicator light), chrome/standard tape equalization and a power switch.

The two VU meters are situated on top of the machine to the



Sansui SC-700

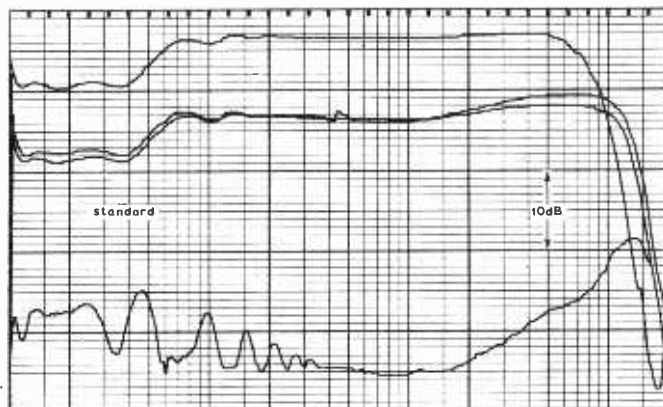
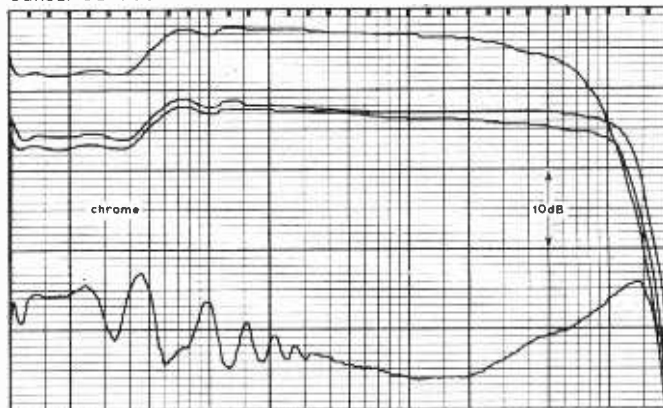

10 20 50 100 200 Hz 500 1k 2k 5k 10k 20k

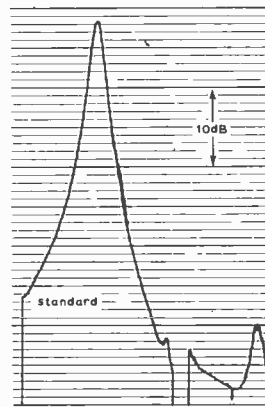
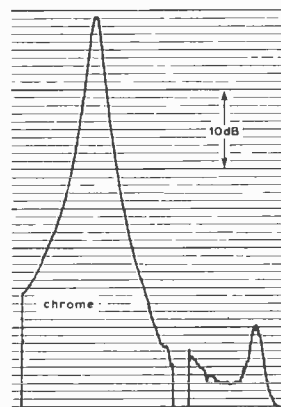

rear on a sloping panel. They are very large (68mm) and light up like Christmas trees in green, red and white; each meter is lit by two 6.5V 0.25A lamps run at 5.4V. The meters are easy to read at a distance which is a better solution to the problem of accidental overload than the flashing lights used on some other machines. Unfortunately the right-hand meter on the test machine did not work (so most of our measurements were made only in the left channel); however, it is only fair to mention that the machine had been flown specially from Japan for our tests and had also undergone two road journeys without having a pre-delivery check. It was the first machine of its type in the country.

On the rear of the machine there is a voltage selection panel (100 to 240V, 50 or 60Hz), a fuse, high- and low-level phono input sockets, phono output sockets and a DIN input/output socket. The machine incorporates 48 transistors (including two f.e.t.s), 16 diodes and two thermistors.

The instruction book is excellent and is well illustrated. The machine comes complete with a full circuit diagram, a cleaning cloth and an angled head 'felt tipped pen' for cleaning the record and replay heads.

Apart from the few shortcomings discussed this is a good machine which can be recommended from the performance point of view but one has to pay highly for the few extra facilities it offers over other Nakamichi machines.

**Teac A-350**

**Total harmonic distortion 2.3%: Signal-to-noise ratio, Dolby out 50dB, Dolby in 53dB: Wow and flutter 0.15%: Cr<sub>2</sub> erase 50dB: Input for OVU; DIN L-0.2mV R-0.2mV, phono L-85mV R-85mV: Output DIN and phono L-550mV R-550mV: Rewind 1m 46s: dimensions 430 × 247 × 200mm: Price £144.**

This machine was lent to us by an independent laboratory who had been evaluating it. If this laboratory found something out of adjustment they put it right. The machine is, therefore, not necessarily representative of production items which will be sold in this country.

The six tape transport control keys have a not-very-pleasant 'loose then stiff' feel although the mechanism itself seems to perform well enough and returns a fairly respectable wow and flutter figure. A long narrow amber lens is illuminated by a spot of light which travels down the length of the lens when the tape is moving in either the record or playback modes. Below the lens is a Perspex light guide and a small lamp. The light path between the lamp and guide is interrupted by a slotted disc. The idea is a good one in that one can see from a distance if a cassette has jammed. The top control panel has two long slider type record level controls and two slider output level controls which are a waste of panel space as discussed earlier. Three toggle switches are used for chrome/standard tape equalization, microphone and DIN or line



input selection, and Dolby in/out with the usual associated Dolby warning light. Between the reasonably sized and fairly well illuminated VU meters is an unnecessary peak level warning lamp. One would have thought the only reason for an indicator of this sort was to be able to see, from a distance, if overload was occurring. As the lamp on the Teac is set at the bottom of a tube one would need to hang from the ceiling to see it from any distance. On the front of the machine are jack sockets for two microphones and a pair of headphones. The DIN and phono input and output sockets are set in a recess at the back of the machine. A fuse is fitted underneath.

The frequency response is 'Nakamichi-like' and the matching between channels is very good indeed. The machine has a good, average, all-round performance. We cannot comment on the instruction book as an English version is not yet available.

**Uher compact report stereo 124**

**Total harmonic distortion 3%: signal-to-noise ratio 50dB: Wow and flutter 0.18%: Bias oscillator frequency 100.8kHz: Input for OVU (all DIN), radio L-3.7mV R-4mV, line (phono) L-150mV R-161mV, car radio (d.c. isolated) L-56mV R-56mV, external microphone L-0.2mV R-0.2mV: outputs, radio L-0.8V R-0.8V, car radio L-45mV R-45mV, speaker 2V across 4Ω: Rewind (mains power) 2m: Dimensions 185 × 180 × 57mm. Price £185.**

The Uher 124 differs considerably from the other machines tested and is designed to function both as a portable recorder and as an adjunct to a high-quality audio system. It is the smallest machine we tested (by a long way) it is the only one to contain an internal loudspeaker and the only one capable of operating from a variety of power sources.

The 124 can be powered by six small pen-cells, a lead acid accumulator, a nickel cadmium battery, a 12V car battery or from the mains (100-130V, 200-240V, 50 or 60Hz) using a mains power unit. An accumulator or the batteries slip into a compartment at the rear of the machine and, if desired, the mains power unit can be plugged in as well. The machine will then run from the mains and the accumulator will be recharged. The mains power unit is the same size as the accumulators and can be slid into the battery compartment for continuous mains operation if required. We noticed a fairly high level of hum when the mains power supply was fitted inside the machine.

The cassette is loaded into a slot in the front of the machine 'thin end first'. The tape transport mechanism has two main controls, a three-position (forward, reverse and neutral) fast wind lever and a five position 'joy stick' type switch. With this switch up the machine is switched off. When the lever is moved to the central position the machine is switched on provided that a cassette is in position. Moving the lever to the left or right selects play in the forward or reverse direction (the machine has a four element head so there is no need to turn the cassette over to play the other 'side'). Moving the switch down puts the machine in the pause condition. A small moving-coil indicator shows which 'side' of the cassette is selected. When playing back, on reaching the end of the tape the machine automatically reverses and plays back the other 'side'. One can record only in one direction.

Teac A-350

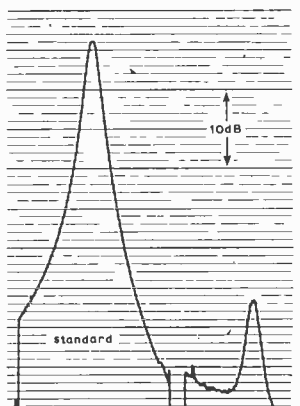
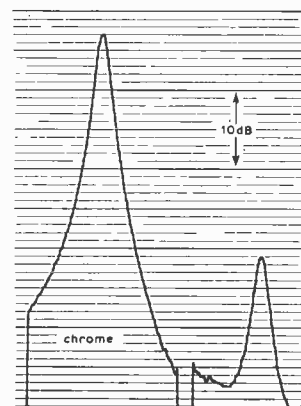
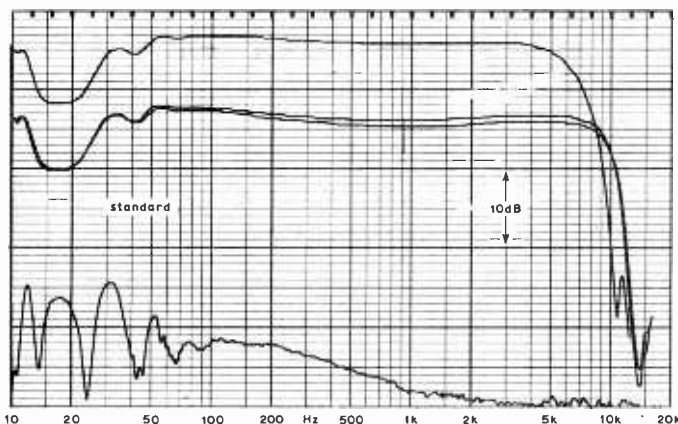
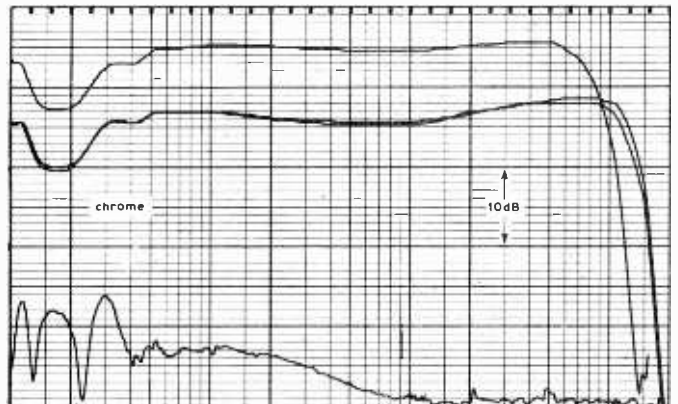





Other front panel controls include four push-buttons which switch the internal speaker off, select internal or external microphone, automatic level control on/off and select record. The internal microphone is fitted to the front panel and is a low-voltage capacitor type. When automatic level control is selected the time constant in use is determined by which input socket is being employed. A manual rotary record/playback level control and a single VU/battery-level meter completes the front panel. No means is provided for adjusting the stereo balance and a mono/stereo switch is not included.

On the rear of the machine are two sockets, one for connection to a car radio and the other for connection to the mains power supply unit when it is being used separated from the machine.

Three sockets on the side allow the connection of headphones or loudspeakers, line in and line out, and a variety of accessories including remote control units. Access is provided to the unused record sections of the record/playback head and another pin allows the motor speed to be varied remotely.

Uher compact stereo 124

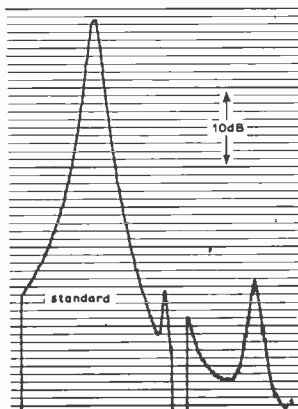
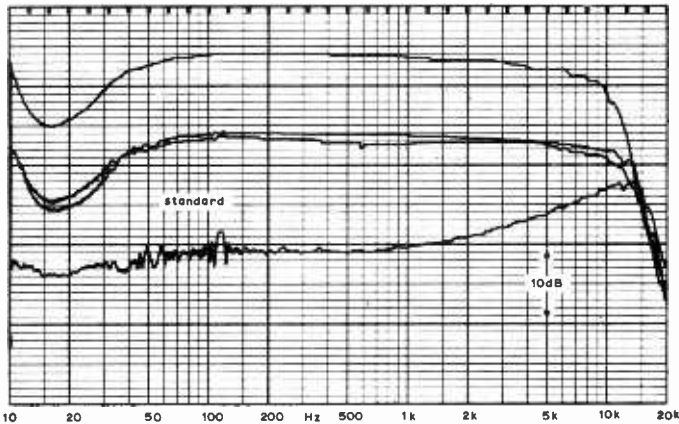

Considering that it has not a noise reduction system the signal-to-noise ratio is very good indeed and has been achieved by using specially designed high-inductance heads. Unfortunately the price which has been paid for this noise reduction is a fairly poor crosstalk performance. All other aspects of the performance are good and Uher are to be congratulated for packing so much into such a small space.

The tape transport mechanism seems to be very choosy when it comes to cassettes, and cassettes which run smoothly on other machines will not necessarily be accepted by the 124.

As soon as the equalization standard for chromium dioxide tape is decided Uher intend to fit a chrome equalization circuit which will be selected automatically when a chrome cassette is put into the machine.

**Wharfedale DC9**

**Total harmonic distortion 2.2%: Signal-to-noise ratio, Dolby out 49dB, Dolby in 54dB: Wow and flutter 0.18%: Bias oscillator frequency 102.2kHz: CrO<sub>2</sub> erase 50dB: Input for 0VU, DIN and phono L-39mV R-39mV, microphone L-0.2mV R-0.2mV: Output DIN and phono L-1V R-1.1V: Rewind 2m 11s: Dimensions 279 x 216 x 89mm: Price £110.**

Taking into account normal production and adjustment tolerances the machine is identical to the Bell & Howell DES 1700 as far as

Wharfedale DC9

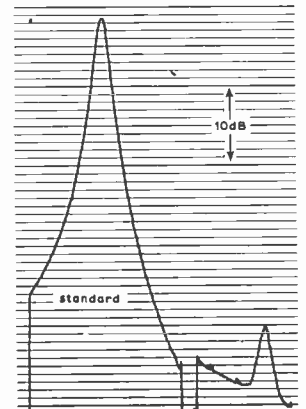
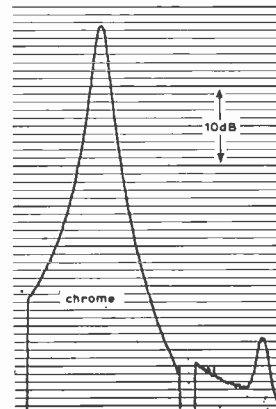
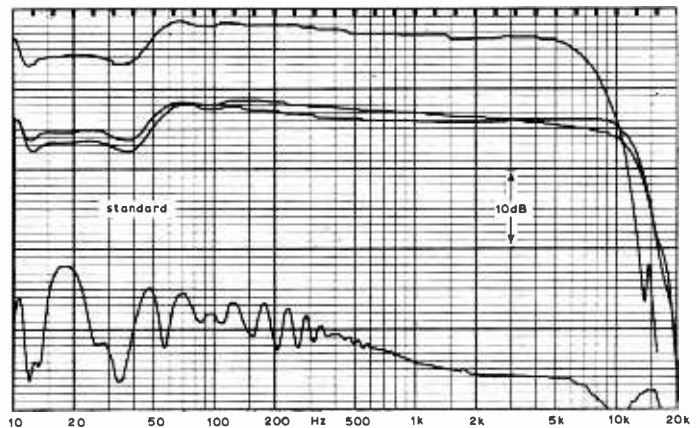
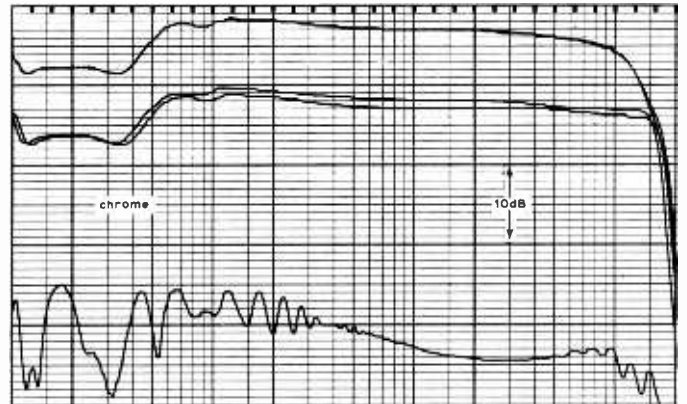

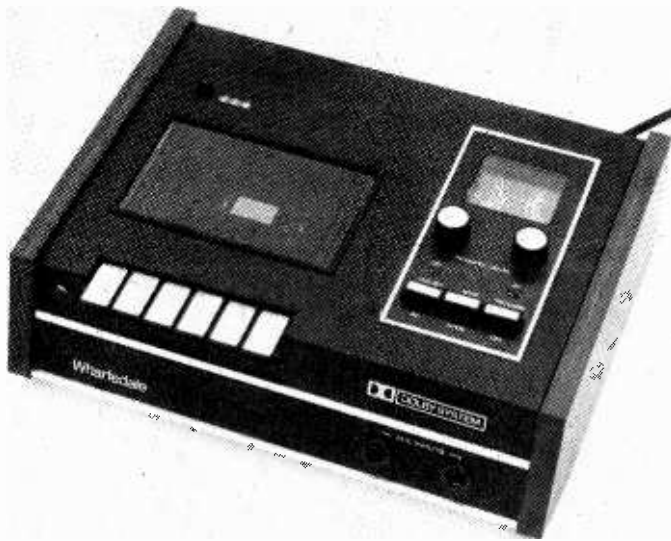

performance is concerned and is in fact another product of Nakamichi Research. The DC9 is smaller than the 1700 and its top mounted controls are perhaps more convenient to use with the exception of the two rotary recording level controls. To properly fade a stereo signal one has to use two hands, not a good point. Three push-button switches are employed for Dolby in/out, chrome/standard tape equalization and power on/off; there is not a mono/stereo switch. Like the Bell & Howell there are three indicator lamps (power, record, Dolby). Microphone input is by front panel jack sockets and DIN and phono output/input sockets are provided on the rear of the machine. There is also an output level control on the rear of the machine.

The instruction book is fairly good but it can be a little difficult to follow because it is written in three languages badly laid out.

The choice between Wharfedale and Bell & Howell must be made purely on small points which are a matter of personal preference; styling, size, rotary or slider recording level controls, mono/stereo switching, and input/output socket arrangements. The frequency response of the machine is good.

**Listening test**

Last month we mentioned that we had carried out a listening test in which we compared an open-reel tape recorder with one of the cassette recorders we had tested. The object was to assess what one lost in performance, if anything, if one bought a cassette recorder. To do this we assembled two listening panels. The first panel was made up from both males and females who had no special technical or musical knowledge. The second panel, all male, was chosen for either technical or musical ability (in some cases both) and comprised members of the editorial staffs of our associated publications: *Electrical and Electronic Trader*, *Electrical and Radio Trading*, *Electrical Review and Electronics Weekly* together with the technical staff of *Wireless World* and two music critics.

Acoustically the room used for the tests did not differ widely from conditions one would find in a large living room. The equipment, with the exception of the loudspeakers, was situated in an adjacent room so that the listeners did not know which machine they were hearing.

Material from disc records was used as a standard against which the recorders were compared. For disc reproduction we employed a Garrard Zero 100s turntable fitted with a Shure V15 Mk 2 cartridge, a Bang and Olufsen 3000 tuner amplifier and a pair of the folded horn loudspeakers designed by John Greenbank and described in the January 1972 issue of *Wireless World*.

The cassette tape deck was the Bell & Howell DES 1700 (reviewed last month) and the open-reel tape deck was a Tandberg 3000X. Both these machines cost about the same (within a few pence).

We then had a difficult problem to resolve. The Tandberg was a three-speed machine (1 7/8, 3 3/4 and 7 1/2 i.p.s.). At what speed should we run it for the comparison tests? A good argument could be put forward for using each of these speeds. In the end it was decided

to use the Tandberg at its best at 7 1/2 i.p.s. It should be pointed out that at this speed the Tandberg is much more expensive to run in terms of tape cost than the cassette machine.

As we were using the open-reel machine at its best we did the same for the cassette recorder and operated it with the Dolby noise reduction system switched in and with a chromium dioxide tape cassette. The open-reel machine was used with the reel of low-noise Tandberg ferrous oxide tape that came with it.

To the user, although both machines cost the same, they have different advantages and disadvantages. The cassette machine was the easiest to operate, it had a noise reduction system and had all the advantages one normally associates with cassettes from the handling point of view. The Tandberg did not have a noise reduction system, it had three speeds and offered such facilities as sound-on-sound, sound-with-sound, off tape monitoring (because of the three heads) etc.

In the listening tests the Tandberg came out slightly better than the Bell & Howell on signal-to-noise ratio. We feel, however, that this may not have been the case if the machines had been in the same room as the listeners because the mechanical noise from the Tandberg was much higher than that from the Bell & Howell. In a smallish room this could have swayed the listeners in favour of the Bell & Howell on this point.

We chose extracts from four discs and these were recorded on the cassette and open-reel machines.

The inexperienced panel listened first to the disc and then to the two recorders and were asked to say how good the recordings were when compared to the disc. They were given four choices: the same as, slightly worse than, much worse than and very much worse than. They were asked to make their judgment after assessing background noise, 'tonal quality' and 'clarity'.

When analysing the results, if a person thought the cassette recorder was slightly worse than the disc and the open-reel recorder was much worse than the disc one point was scored in favour of the cassette machine. If a listener thought that the machines both sounded slightly worse than the disc or both sounded much worse than the disc a zero was scored. In other words, one point was scored for each category difference between the two machines. The results are summarized in Fig. 11(a). It can be seen that seven listeners thought that the cassette machine sounded one category better than the open-reel machine, one thought the open-reel machine sounded better and one said that both machines sounded the same. One must conclude that as far as our inexperienced panel was concerned the cassette tape recorder was to be preferred.

(a)

	Cassette recorder	Open reel recorder
overall	1 1 1 1 1 1 1	1 0

(b)

	Cassette recorder	Open reel recorder	
bass response	1 1 1 2 1 6	1 2 2 1 1 7	0 0 0 0 0 0 6
treble response	1 1 1 1 4	1 2 1 2 1 2 1 1 1 1 1 14	0 1
noise	1 1 1 3	1 1 1 1 1 1 1 1 8	0 0 0 0 4
distortion	1 1 2 1 2 1 1 2 1 2 1 15	1 1 1 1 1 1 5	
wow & flutter	1 1	1 1 1 3	0 0 0 0 0 0 0 7
overall	1 1 1 1 1 5	1 1 1 1 1 1 1 1 1 9	0 0 2

Fig. 11 (a) Inexperienced listeners thought the cassette best while, (b), the panel of experts preferred the reel-to-reel machine.



The experienced panel was asked to compare the recorders with the disc on the following points: bass response, treble response, signal-to-noise ratio, distortion, and wow and flutter. They were also asked to give an overall assessment of performance. For most of these points they were asked to place a recorder into one of six categories on a scale similar to that already detailed for the inexperienced listeners. Again a recorder scored one point for each category it was judged better than the other machine in relation to the disc. If both machines were given the same rating a zero was scored. The results are summarized in Fig. 11(b). The total score is given in the bottom right-hand corner of each 'block'.

The bass response of both machines was judged to be very similar with 6 points for the cassette, 7 for the open-reel and 6 listeners saying there was no difference. All the listeners thought the recorders were not as good as the disc on this point by a fairly large amount.

The open-reel machine was judged to have a much better treble response than the cassette by 14 points to 4, with one listener saying there was no difference. In general the reel-to-reel machine was thought to be only slightly worse than the disc.

The open-reel machine had the edge on signal-to-noise ratio but, as already stated, was mechanically noisier.

The sample of the Tandberg we used suffered from high-frequency distortion, which is reflected in the results. The cassette machine was rated much better than the open-reel by 15 points to 5 and slightly worse than the disc.

Both machines were rated the same for wow and flutter and no different from the disc. Two of the listeners complained that the material we used was unsuitable for this test.

Overall the experienced listeners preferred the Tandberg by 9 points to 5, a ratio of about 2:1. If one takes the difference between the scores for each aspect of performance and adds them up, this 2:1 ratio appears again. It is probably fair to assume that the distortion of the high frequencies on the Tandberg was an isolated case and does not occur on all machines of this type. If this was indeed so then the open-reel machine must be classed as being much better than the cassette recorder.

One possible explanation for the differing views of the two panels is that some members of the inexperienced panel may have grown accustomed to listening to small radio sets and medium-priced radiograms and had come to prefer this kind of sound.

It would appear that when one buys a cassette recorder one trades performance and versatility for convenience in use. However the cassette recorder we tested, while not performing as well as its reel-to-reel counterpart, put up a creditable performance and many people would think that the trade-off was worthwhile.

### Caring for, and using, a cassette recorder

If you buy a cassette recorder there are two other essential purchases you must make besides a supply of blank cassettes. These are a small bottle of isopropyl alcohol and some 'cotton wool buds' (small balls of cotton wool attached to short wooden sticks often used in baby care). Both items cost only a few pence from a chemist.

Cassette recorders employ heads with an extremely narrow gap that soon becomes clogged with oxide from the tape which lifts the tape away from the heads causing poor erase and useless recordings. The oxide also builds up on other parts which come into contact with the tape; in particular the pinch wheel. The wow and flutter figure of one of the recorders tested dropped by 50% after the pinch wheel and tape path had been cleaned.

The rule is to clean the heads and the tape path after five or ten cassettes of playback time and *before every recording is made*. This is no great hardship as the task takes only a few seconds.

The average machine has a very large number of internal preset adjustments which will probably require periodic attention, and mechanical parts will require cleaning and lubricating at intervals. These are jobs for the manufacturer and we feel that it would be reasonable to return the machine every six months to a year for overhaul. Some manufacturers in fact recommend this.

Cassettes should be stored in a cool place and the surface of the tape should not be touched with the fingers. It is a good practice after playing back a recording not to wind back the tape if the cassette is to be stored. This is because fast wind spooling is not

as even as spooling during record or playback so there will not be as much stress stored in the tape and, consequently, there will be less tendency for the coils of tape to adhere to one another during storage.

It is false economy to buy cheap cassettes as these could contain abrasive tape that will soon wear out expensive heads. There may also be a tendency for such cassettes to stick or jam.

When recording it is usually better to err on the side of under-recording rather than the converse.

All of the machines had some means of switching the drive motor off automatically should the tape stop moving for any reason. In addition some machines had a solenoid which operated under these conditions to disconnect the complete drive system, having the same effect as pressing the stop button.

If a recorder is not fitted with the automatic drive disconnect mechanism it is essential not to leave the machine with the play button pressed and the motor not running. If you do, a flat on the pinch wheel will develop which will cause wow and flutter.

### The ideal machine?

We are of the opinion that not one of the machines tested was ideal, either from user or performance point of view. If features of the different machines were to be combined to produce an ideal machine we would choose:

The National tape transport controls with the Advent or the Nakamichi mechanism. The frequency response of the Akai. The versatility of the Uher. The Sansui VU meters. The machine would also have slider type recording level controls (or perhaps the Advent level system), a mono/stereo switch, a choice between chrome and standard tape equalization, a Dolby noise reduction system with a calibration oscillator, a preset output level control, a choice of phono or DIN input/output sockets, a headphone monitoring jack, and twin microphone jacks. Such a machine would probably be very expensive. In the reports we have already stated our opinion regarding output level controls. Another point which we found very annoying was the absence on some machines of a mono/stereo switch. This switch is usually only a single-pole on/off type that parallels the two channels at the input for mono operation. Without it, when recording from a mono source, all the information is in one channel only and half of one's audio system is being wasted. Apart from all the sound coming from one corner of the room one loses the impression of spaciousness normally associated with playing a mono signal through a stereo system. A stereo/mono switch can easily be added externally but this is not very convenient.

Finally, a number of the machines came equipped with a non-standard mains plug (Japanese) which we think is bad practice.

## Sixty Years Ago

April 1912. *The Marconigraph* contained an article by H. Riall Sankey 'Mechanical Analogies Applied to Wireless' which describes the action of a tuned circuit in a manner that would probably be welcomed by many newcomers to the art today. "If a weight is dropped into still water concentric wavelets will be formed. If the weight is too large or the height from which it is dropped is too great, not only will waves be formed, but there will be splashing, and this splashing corresponds to the brush discharge already referred to. If the weight be fixed to a horizontal spring, and a force is momentarily applied to the weight, it will oscillate in a well-known manner. It will hit the water, and each time it does so will produce waves in the manner already pointed out, and if the energy is too great there will be splashing as well as waves. A smaller weight placed underneath the big one held up by a horizontal spring, will also form an oscillatory system, and will be put into motion by the large weight first hitting the small weight, which, in its turn, will hit the water and produce the waves. Matters can be so arranged that the energy imparted to the small weight at each impact is sufficient to produce the maximum amount of wave without any splashing . . .

"It is obvious that a necessary condition to carry out this effect is that the small weight shall always be just at the top of its path as the big weight comes down to hit it — that is to say, both oscillatory systems must have the same time-period, or, in other words, they must be tuned."

This analogy explained the action of a transmitter of the time which consisted of a tuned transformer (large weight) to set the frequency of the spark and provide a means of feeding energy into the system. The small weight represents the aerial coupling transformer.

# World of Amateur Radio

## "Top band" season

The latest 160-m bulletin issued by Stew Perry, W1BB, confirms impressions that the band is opening earlier and closing later this year, in line with lower sunspot activity, producing DX that would have been unthinkable a few years ago on this m.f. band. Scotland to West Australia, Eire to Hong Kong, Alaska to Hong Kong, Europe to South America are among the many contacts reported. ZP8AY, Ascension Island, made several hundred contacts with Europe, United States, West Indies, Brazil, etc before closing towards the end of 1971. There is hope that another station on the island, ZD8CS, may open on the band soon. The Czech top-band station, OK1ATP, has made more than 200 contacts with the United States since 1968. Stew Perry himself made 12 transatlantic contacts during the tests of January 9th. He rates long-wire Beverage aerials as 'No 1 for receiving only' listing other effective top-band aerials as verticals (quarter-wave, or less with top loading) providing they are used with multiple ground radials, inverted-vee sloping dipoles, inverted-vee dipoles, dipoles and long-wire types. One American station, W4BRB, is reported to be using 300 sq ft of aluminium foil in thin strips to increase ground capacity.

## New look at mechanical TV

In a recent letter to Michael Hallett, manager of the I.T.A.'s Television Gallery, Chris Long, of East Hawthorn, Victoria, Australia, reported that a new low-definition television system which he has developed is being used by a fast-growing group of Australian amateurs on 1.8 MHz, as a 'moving image' alternative to slow-scan TV. The system, with a standard of 48 lines, 4 fields, uses mechanical scanning with a Nipkow disc but with direct scanning rather than flying-spot techniques to allow scenes illuminated in natural light to be transmitted. A member of the Australian group has developed means of adapting almost any oscilloscope to provide a suitable monitor. The restricted bandwidth permits transmission on h.f. and the Australians are hoping that the idea will

spread internationally. Chris Long has also built a 30-line scanning unit as part of a demonstration he is giving of mechanical television systems and has acquired a tape of video signals taken from the I.T.A.'s 'Phonovision' 30-line video disc.

In the U.K. amateur TV licences have risen to 214, and there are also numbers of enthusiasts who confine their activity to closed-circuit operation. The British Amateur Television Club's next convention is to be held on Saturday, September 16 at I.T.A. headquarters in Knightsbridge, London. *CQ-TV*, the bulletin of the club, has started a series of articles on 625-line PAL colour.

One of Europe's keenest exponents of slow-scan TV, Professor Franco Fanti, IILCF of Bologna, Italy, has just published two new booklets 'Slow scan TV monitor' (Italian text) and 'Slow scan flying spot scanner' (Italian text plus English summary) giving full construction details of these two essential items of slow-scan equipment.

John Tanner, G6NDT/T, is now active from Andover with 100 watts vision in the 70-cm band.

## Local activities

Probably nobody knows just how many active local societies, clubs and groups devoted to amateur radio exist in the U.K. There are over 330 (including a number overseas) affiliated to the R.S.G.B. but almost certainly there are many less formally constituted groups. Some have permanent club rooms, some meet in members' homes weekly or monthly. Some wax and wane in a short space of time, some maintain successful activity over many years, others vanish almost without trace. Popular activities include junk sales, morse classes, club 'project' evenings, and 'natter nites' (*sic*). But the mainstay is the informal lecture, and these reflect current interests to a remarkable degree. The current crop of lectures includes such topics as slow-scan TV, crystal-controlled clocks, s.h.f. and v.h.f. equipment, problems of r.t.t.y., ham radio in the South Pacific, aerial circus, early days of amateur radio, video tape methods, converting business radio

equipment for v.h.f. use, test equipment and even nuclear physics — with such variety clearly the spell of local meetings has by no means vanished!

Two popular annual events covering a wider area loom up. The 18th annual v.h.f./u.h.f. convention at the Winning Post Hotel, Whitton, near Twickenham, Middlesex, is on Saturday, April 22nd. The Northern Radio Societies Association convention/exhibition is at Belle Vue, Manchester, on Sunday, May 7th.

The 1972 Affiliated Societies Contest was won by G3SSO, the station of the Government Communications Headquarters' amateur radio society at Cheltenham. Runner-up was G3BEA, club station of British European Airways. More than 50 societies entered.

## U.S.S.R. "50" stations

Since February 23rd, the Radio Sport Federation of the U.S.S.R. has been operating five special stations as part of a 'radio expedition' to commemorate the 50th anniversary of the founding of the Union of Soviet Socialist Republics in 1922. In the first week, the stations used the call signs UA50 (UA fifty) A to E, with the second letter of the prefix changing each week until June 7th. To judge by the strong signal and snappy procedure of UA50B when I worked the station on 3.5 MHz, this group of stations intends to register many thousands of contacts.

## In brief

To encourage more s.s.b./c.w. activity on v.h.f. bands, Tom Douglas, G3BA, suggests that between the hours of 19.00 and 23.00 local time, stations should send CQ calls every hour on the hour. . . . The Australian Ionospheric Prediction Service (whose interest in transequatorial propagation was noted in the February 'W.o.A.R.') has invited co-operation from amateurs in studies of transequatorial openings and v.h.f. propagation between Australia and the Antarctic. . . . The 21st anniversary of the University of Keele will include special operation of its amateur radio society's station G3UOK on April 22 on 3.5, 14 and 144 MHz. . . . Violent ionospheric storms were reported in the third and fourth weeks of February. . . . The White Rose Mobile Rally on Easter Sunday, April 2, will be at Lawnswood High School, Leeds 6 (details, R. Short, G3YEE, Bradford 664220). . . . North Midlands mobile rally is on April 16 at Drayton Manor Park, near Tamworth. . . . Dr John Saxton, who was R.S.G.B. president in 1970, is being invited to be president in the Society's Diamond Jubilee year of 1973. . . . Royal Signals Amateur Radio Society is to operate GB3RCS, from May 14 to 22 to mark the 75th anniversary of Marconi's experiments over distances of up to eight miles in May 1897 when the Royal Engineers (from which Royal Signals was formed) assisted.

Pat Hawker, G3VA

# Miniature Automatic Telephone Exchange Modifications

The writer built a telephone exchange similar to the one described by G. F. Goddard and suggests some modifications

by P. F. Gascoyne

I was pleased to read the article 'Miniature Automatic Telephone Exchange' by G. F. Goddard in the February issue if only to find out that I am not the only reader of *Wireless World* who has his own telephone exchange at home. I was surprised that his did not contain more electronics, although I must confess that mine, now about 12 years old, has none. There are many points of similarity between the two systems. U1, U2 and relays RLC, D, E and J all have their counterparts. Perhaps the comments below may be of use to readers.

## Relays

Post Office 3000 relays with slugs are not so common as those without, so other methods of slugging relays could be useful. For instance, for RLB one could use a freewheel diode across the coil (connect the anode to the negative side of the coil). For RLE try using a  $1k\Omega$  coil shunted by a  $820\Omega$  3W resistor (this is used in my system). Relays RLD, F, G and H can be slugged with either a freewheel diode or, if longer delays are required, an electrolytic capacitor (with a  $470\Omega$  series current-limiting resistor) across the coil. The slug on RLJ is, I believe, to stop the relay chattering to the 50Hz ring current. In this case a freewheel diode would not work. Some possibilities are: an electrolytic straight across the B coil (include some current-limiting resistance in the lead from RLJ/1); use a frequency much higher than 50Hz for the calling signal (see below) so that slugging is unnecessary; take a leaf out of the G.P.O.'s book and provide the slugging action by using a contact of RLJ to short circuit the holding (B) coil until it operated (Figs 1(a) and (b) illustrate possible methods using this idea). In Fig. 1(a) the  $47\Omega$  resistor saves damage occurring if RLJ/1 should make before RLJ/4 breaks. In Fig. 1(b) an extra contact is saved.

Of course, relays RLF, G and H would ideally be replaced by one relay and a transistor multivibrator.

Normally in an exchange, the dial pulses are received by a fairly standard 3000 type relay. However, exchanges also have two relays associated with each line, a 'line' relay to detect when the hand-set is lifted to make a call, and a 'cut off' relay to disconnect the line relay once the

equivalent of U1 has found the calling line. Thus the calling line is then connected directly to the 'impulsing' relay with nothing in shunt. Mr. Goddard's circuit saves the use of the 'line' and 'cut off' relays but at the expense of having  $5.6k\Omega$  in shunt with the impulsing relay. This could slug a 3000 type relay so that it would not respond correctly to the dial pulses. This effect is negligible with a high speed relay because of its much smaller inductance. However, double pole high speed relays are not as common as single pole types. A possible alternative is to use a P.O. type 23 (this is a modern miniature plug-in relay about 25mm high with a transparent

cover), or one of its commercial equivalents. Typically one with a coil resistance of  $2.5k\Omega$  has an inductance of around 24H when operated. If this were used, when the dial contacts broke during an impulse, the relay current would decay with a time constant of about 3ms. Since the release current is around 30% of the normal current, the release will be delayed by a similar time giving a total release time of the order of 14ms, i.e. about the same as an un-slugged 3000 type. (A dial returning at normal speed gives 10 impulses per sec. with a 66% break ratio, i.e. each pulse is 66ms break, 34ms make.) For RLC's other function, that of stopping U1, there should be no problems.

## Ringing

To provide a better sound when operating the bells on 50Hz I would advise the following adjustments. Slacken the screw holding the central magnet and adjust so that the armature is just touching one pole piece and there is an 0.008in gap at the other. Set the clapper so that when it is moved slowly from side-to-side it just fails to reach the bell gongs.

## High frequency ring current

Some years before the G.P.O. brought out their 'Trimphone' some of the telephones on my exchange were smaller than a 'Trimphone', and emitted a squawking noise to signal a call. How? By scrapping the bell and feeding a high-frequency ring current (produced by a buzzing high speed relay) to the earphone of the handset, via a  $0.1\mu F$  capacitor connected across the cradle switch. The relay produces a 600Hz sawtooth waveform of 40V peak-to-peak (a square wave from a multivibrator would probably be just as effective and certainly more reliable). In my exchange the ring tone is produced, from the ring current, by bridging a small capacitor across the equivalent of the break section of contact RLH/3. The circuit of G.P.O. telephones includes a transformer with three windings (some non-G.P.O. telephones of similar external appearance do not) and some other components which match the microphone and earphone to the line. These components form a semi-balanced bridge circuit which prevents the speaker hearing

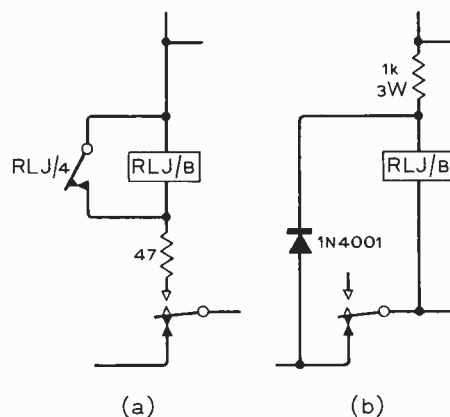

Fig. 1. Alternative ways of slugging relay RLJ/B

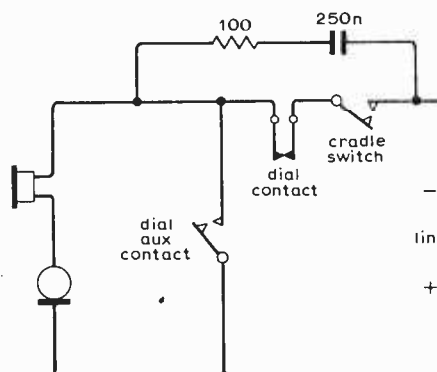

Fig. 2. Ringing circuit used by the writer which does away with the bell. The calling note is produced by the earpiece.

himself too loudly. These complications improve efficiency, but are not essential if all the lines are short in length; thus, for my telephones, I used the circuit in Fig 2. The 100nF capacitor has been increased to 250nF and forms part of a spark quench circuit for the dial as well. It is supposed to be bad to put d.c. through the

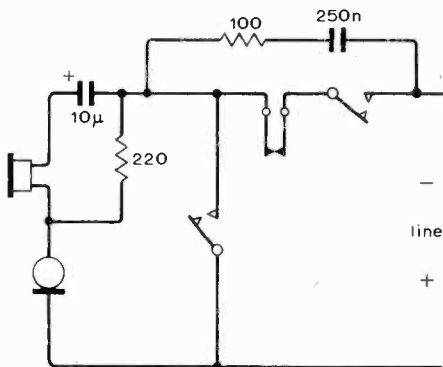

Fig. 3. Similar to Fig. 2 but for use with modern balanced armature earpieces.

earpiece. I have had no trouble with moving-iron type earpieces, but for the modern balanced armature types, it could cause the armature to be driven up against one pole. For these types, therefore, I would suggest a circuit like Fig. 3. The electrolytic need be only a few volts working but watch the line polarity. The auxiliary dial contact short circuits the dial during pulsing, to avoid unpleasant clicks in the earpiece. There are actually two sets of auxiliary contacts; one set is permanently connected to the pulsing contacts and the other, being spare, is bent clear and used as the cradle switch contact.

### Power supply

Although there is something to be said for switching a series resistor into the main supply, since otherwise, on no load, the reservoir capacitor will charge up to the peak transformer voltage, I am not sure that the use of an auxiliary battery supply is worth while. If the mains supply is left 'on' permanently the extra power consumed in the idle condition is small, while turning it 'off' does not really increase the safety, since at any time a telephone can be lifted turning it 'on' again. Talking of safety, though, it would be advisable to adopt the recommendations given in Mr N. Monk's letter in this issue. I would also advise connecting a 0.25A thermal cutout in place of, or in series with, FS2. This will protect the uniselector coils from overheating if any fault should cause them to be permanently energized (when their current will rise to 0.75A as opposed to an average of 125mA when stepping).

Finally there is a couple of mistakes on the original circuit diagram. RLJ/3 should be a normally closed contact, and the zener diode, D<sub>s</sub>, should be reversed.

# April Meetings

*Tickets are required for some meetings: readers are advised, therefore, to communicate with the society concerned*

## LONDON

6th. IERE — "Visual telecommunication systems: a review of some technical problems" by I. Macdiarmid at 18.00 at the Engineering Lecture Theatre, University College, Torrington Pl., W.C.1.

10th. IEE — "B.B.C.'s television management information systems" by C. Lashmar and G. D. Cook at 17.30 at Savoy Pl., W.C.2.

11th. IEE — Discussion on "Magnetic bubbles" at 17.30 at Savoy Pl., W.C.2.

11th. IEE Grads — "Minicomputers and automation" by J. Woodcock at 18.30 at Savoy Pl., W.C.2.

11th. AES — "The control of acoustic feedback by room equalization — some recent investigations" by J. H. Kogen at 19.15 at the Mechanical Engineering Dept., Imperial College, Exhibition Rd., S.W.7.

12th. IEE — "Computer programming as an engineering discipline" by Professor C. A. R. Hoare at 17.30 at Savoy Pl., W.C.2.

12th. SERT — "The Philips video cassette recorder" by R. Smith at 19.00 at I.T.A., 70 Brompton Rd., S.W.3.

13th. IEE — Discussion on "The electrical and electronic systems in Concorde" at 18.00 at Savoy Pl., W.C.2.

13th. RTS — Fleming memorial lecture "A television service fit for artists" by Dr. G. B. Townsend at 19.00 at the Royal Institution, Albemarle St., W.1.

17th. IEETE — Panel meeting on "Electronics" at 18.00 at IEE Lecture Theatre, Savoy Pl., W.C.2.

18th. IERE — "Modern dynamic measurement techniques" by J. D. Lamb and P. A. Payne at 18.00 at the Engineering Lecture Theatre, University College London, Torrington Pl., W.C.1.

19th. Inst. Nav. — "Long haul airlines and satellite communications" by J. O. Clark at 17.00 at the Royal Aeronautical Society, 4 Hamilton Pl., W.1.

19th. IERE — "The consequences of innovation on society" by R. Loveridge at 18.00 at the Engineering Lecture Theatre, University College, Torrington Pl., W.C.1.

20th. IEE — Colloquium on "Microwave mixers and mixer diodes" at 14.00 at Savoy Pl., W.C.2.

24th. IEE — Discussion on "Aesthetic aspects of aerial design and siting" at 17.30 at Savoy Pl., W.C.2.

25th. IEE — Colloquium on "Developments in oscilloscopes" at 10.00 at Savoy Pl., W.C.2.

25th. IERE/Inst. Nav. — Colloquium on "Flight deck displays and instrumentation for future civil short-field aircraft" at 10.30 at Mullard House, Torrington Pl., W.C.1.

26th. IEE — Discussion on "Coaxial digital transmission at 120M bits" at 17.30 at Savoy Pl., W.C.2.

27th. IEE — Kelvin lecture on "Crystals" by Prof. F. C. Frank, at 17.30 at Savoy Pl., W.C.2.

## BIRMINGHAM

6th. SERT — Colour television forum — demonstrations and lectures by British television manufacturers at 19.30 at The Byng Kendrick Suite, University of Aston, Gosta Green.

20th. IEE Grads — "Electronic organs" by J. D. Ward at 19.30 at the MEB Offices, Summer Lane.

## BRISTOL

20th. SERT — "Thorn 8000 colour television receiver" by A. E. Cullum at 19.30 at Cabot House, Bristol Polytechnic, Ashley Down Road.

## CAMBRIDGE

6th. SERT — "Pulse code modulation" by C. G. Williams at 19.30 at Cambridge College of Technology, Collier Road.

## CARDIFF

25th. IEE Grads — "Communications; tomorrow's world" by T. Rowbotham at 19.00 at U.W.I.S.T.

## CARLISLE

12th. IEETE — "Colour television" by A. D. Campion at 19.30 at the Technical College, Victoria Place.

## CARMARTHEN

19th. IEETE — "Communication by satellite" by V. C. Meller at 19.30 at the Carmarthen Technical and Agricultural College.

## CHELMSFORD

25th. IERE/IEE — "History of the television camera tube" by W. Turk at 18.30 at the Civic Centre.

## DUNDEE

18th. IEE Grads — "The planning and development of v.h.f. networks for television" by T. Sykes at 19.30 at Fulton Bldg., Dundee University.

## EVESHAM

18th. IEE Grads — "From cylinder to stereo" by G. Garside at 19.30 at BBC Club.

## IPSWICH

19th. IEE — "Electronics in medicine" by M. F. Docker at 18.30 at Civic College.

## LIVERPOOL

26th. IERE — "The engineer doctor relationship" by H. S. Wolff at 19.00 at the Department of Electrical Engineering and Electronics, the University.

## LYNEHAM

11th. IEETE — "Micro-electronics" at 19.30 at Royal Air Force Station.

## MALVERN

13th. IERE — "Development of television relay stations" by B. C. Taylor at 19.00 at The Abbey Hotel.

## MANCHESTER

20th. IERE — "U.H.F. mobile radio telephones" by W. H. Wheel at 18.15 at Renold Building, U.M.I.S.T.

20th. SERT — "Disc recording" at 19.30 at Renold Building, U.M.I.S.T.

## NEWCASTLE-UPON-TYNE

5th. IEE — "Satellite television broadcast reception" by K. G. Freeman at 18.30 at the Polytechnic.

12th. IERE — "Recent developments in colour television cameras" by K. G. Johnson at 18.00 at Ellison Building, Polytechnic, Ellison Pl.

## READING

12th. IERE — "Thick film hybrid circuits" by G. Brooke and W. E. B. Baldwin at 19.30 at the J. J. Thomson Laboratory, University of Reading, Whiteknights Park.

## SWANSEA

13th. IERE/IEE — "Measurement of oceanographic variables" by Dr. W. R. Parker at 18.15 at the Department of Applied Science, University College.

## WOLVERHAMPTON

12th. IERE — "An outline of loudspeaker design" by R. H. Fisher at 19.15 at the Polytechnic.

26th. IERE — "The Industrial Relations Act and the chartered engineer" at 19.15 at the Polytechnic.

# New Products

## Polycarbonate capacitors

Housed in flame-proof nylon cases, type CSK polycarbonate capacitors from Seatronics (UK) are designed for high density packaging on printed-circuit boards. Capacitance range is 0.01 to 10 $\mu$ F with  $\pm 10\%$  and  $\pm 5\%$  tolerance over the working voltage range of 63 to 400V d.c. Tan delta is less than 0.003 at 1kHz and the capacitors will withstand a 50% increase in the working voltage for 30 seconds. The normal operating temperature range is  $-55^\circ$  to  $+85^\circ$ C. Seatronics (UK) Ltd, 22-25 Finsbury Square, London EC2A 1DT.

WW305 for further details

## 250MHz timer/counter

A resolution of 1Hz is achievable at maximum frequency on the nine-digit timer/counter by Advance Electronics. Known as the TC14/15, it uses Motorola MECL3 emitter-coupled logic. Input sensitivity is 10mV at an input impedance of 1m $\Omega$  in parallel with 18pF, reducing to 12pF for a sensitivity of 100 or 500mV. The full track version, TC15, will accept plug-in units, one extending the range to 500MHz with a new Plessey i.c. divider and especially useful in mobile communications. (This unit has an input impedance of 50 $\Omega$ .) A fast warm-up 10MHz crystal oscillator

gives a stability of  $\pm 1$  in  $10^7$  from 0 to 50 $^\circ$ C, and an alternate oscillator is available with a stability of  $\pm 5$  in  $10^8$  (after 45 min warm up). Accurate triggering is claimed with 'difficult' waveforms. Trigger level is continuously variable over a range  $\pm 10$  times the sensitivity. Advance Electronics Ltd, Raynham Road, Bishop's Stortford, Herts.

WW331 for further details

## Analogue multimeter

A linear resistance measurement scale and overload protection permitting a.c. mains voltage to be applied to any input range, or any combination of inputs without damaging the instrument, are features of the Philips PM 2404 analogue multimeter introduced in the U.K. by Pye Unicam. The instrument covers both a.c. and d.c. voltages from 100mV to 1000V f.s.d., with an input impedance of 10M $\Omega$ , in nine ranges with a 1:3:10 switching sequence plus currents of from 1mA to 10A f.s.d. in a similar range switching sequence. On resistance measurements a constant current circuit is employed to obtain the linear resistance ranges. With both current and voltage parameters, polarity is indicated automatically by a small moving-coil meter built into the main unit. The overload protection facility permits a.c. or d.c. voltages up to 250V to be connected

to its inputs on any range setting without damage. Overload on resistance or voltage measurements results in full scale deflection of the meter. If it happens on current measurements, then the shunt circuit is protected by a voltage-limiting diode until the fuse blows. Although normally available as a mains operated unit, the PM 2404 can also be supplied with a rechargeable battery pack. Other accessories for the instrument include a high-voltage probe (up to 30kV), a v.h.f. probe (up to 700MHz), and current range accessories for both a.c. and d.c. Pye Unicam Ltd, York Street, Cambridge.

WW316 for further details

## Low-cost sine/square oscillator

Lyons Instruments are producing a new series of low-cost instruments. First in the new 'Interlab' series is the SQ10, a signal source with low sine-wave distortion and fast square-wave rise time together with 50 $\Omega$  source impedance and high output amplitude. Frequency range is 10Hz-1MHz, and signal amplitude 10V p-p (3.5V r.m.s. sine) into 250 $\Omega$  or greater, 5V p-p into 100 $\Omega$ , and 2.5V p-p into 50 $\Omega$ . The

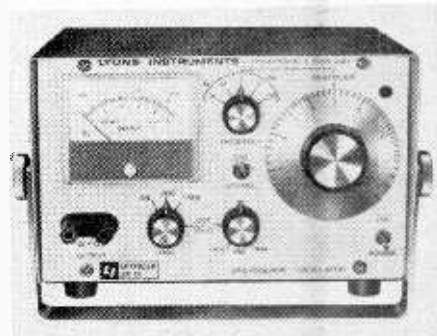

attenuator gives 0-40dB in 20dB steps and vernier. Sine-wave distortion is typically 0.05%, 50Hz-100kHz, less than 0.15% at 10Hz, and 0.5% at 1MHz. Rise time is typically 50ns. Price £57. Lyons Instruments Ltd, Hoddesdon, Herts.

WW318 for further details

## Digital voltmeters

A complete range of 12 digital voltmeters, all of the same size, appearance and panel layout but with different specifications and prices, has been introduced by Solartron. Called the Master Series, they do not offer any advance on present-day specifications but, rather, a wide range of user options within the same basic package. Between the 12 models the measurement options available are d.c. voltage (0-10mV to 1.2kV); a.c. voltage mean sensing (0-100mV to 0-1.2kV); a.c. voltage r.m.s. (0-1V to 0-1.2kV); d.c. ratio; 2/4 terminal resistance; normal speed (10/s) or high speed operation (100/s); isolated outputs and programming; and mains locked integration. Maximum voltage sensitivities are either 1 $\mu$ V (ten models) or 10 $\mu$ V, and

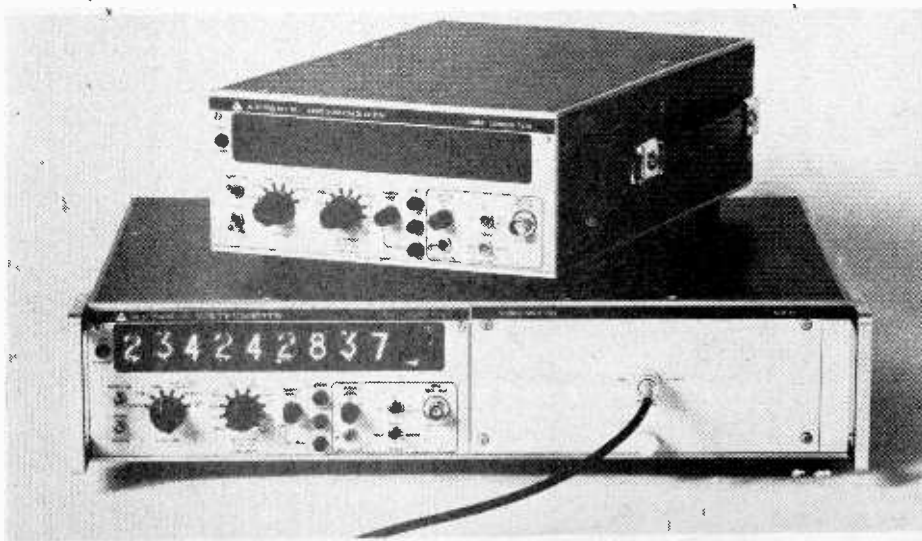



maximum current sensitivity 100pA. Eight models have 6-digit and four models 5-digit displays. Protection against wrong range selection is included, and all inputs are floating. Auxiliary modules available are for a.c. and d.c. current measurement; off-limit detection; pre-selected programming of measurements; linearization, a.c./a.c. ratio,  $\Omega/\Omega$  ratio; and output encoding for paper tape punches, teleprinters etc. Prices for ten models range from £495 to £1,190 with those for two models to be announced. The Solartron Electronic Group Ltd, Farnborough, Hants.

WW333 for further details

## Digital multimeter

Digitest 501 from Dynamco is a small, general-purpose multimeter employing a simple grid selection of function and range. It measures from 100 $\mu$ V to 1kV d.c., 100 $\mu$ V



to 420V a.c., 100m $\Omega$  to 1.5M $\Omega$ , and 100nA to 1.5A (with shunt option) a.c. and d.c. It has a scale accuracy of 0.3% to 1.5% according to the function selected. Price £89. Dynamco, The Street, Shalford, Guildford, Surrey.

WW308 for further details

## Audio modules

A range of printed-circuit plug-in modules intended for use in studios, public address and discotheque sound systems is made by Chadacre Electronics. The range includes a tone control/equalizer, line output amplifier (600 ohm), disc input and microphone pre-amplifiers, VU meter driver, mixing amplifier, headphone amplifier, line-up oscillator, ring modulator, v.c.o., envelope shaper, noise generator, 'phasing' circuit and four-channel pan pot. As well, there is a compressor module, six-channel mixer, a band-pass filter with variable Q, noise generator and spring reverberation unit. all available in cases, but without power supplies. Most units require a 24V power supply. Chadacre Electronics Ltd, 43 Chadacre Avenue, Clayhall, Ilford, Essex.

WW334 for further details

## Wafer switch kits

The N.S.F. model MK rotary wafer switch is now available from Celdis in kit form. The switches have 1 $\frac{1}{2}$ in diameter moulded wafers with up to 12 switching positions

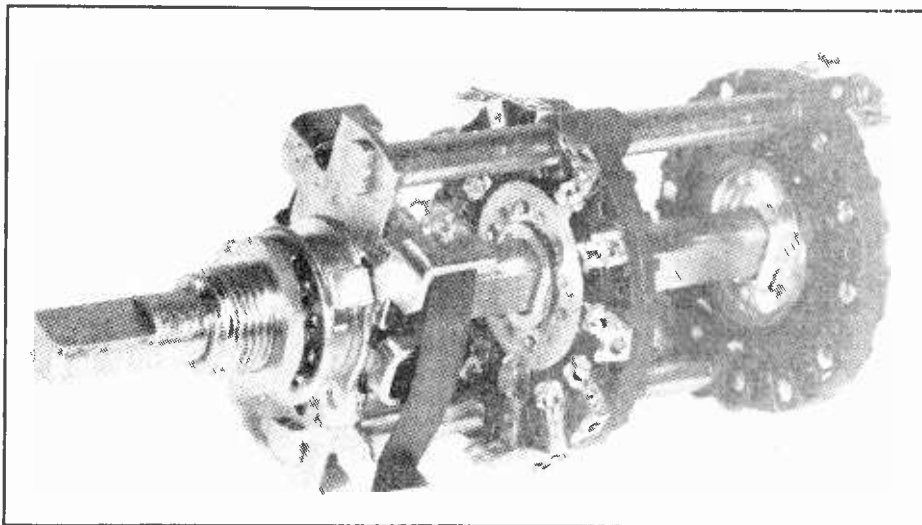

with one, two or four poles per wafer. Contact rating is 5A continuous at 300V a.c./d.c. Switching capability is 60mA at 250V d.c., 150mA at 250V a.c. (r.m.s.). Shaft assemblies have a standard index mechanism with an operating torque of 25oz. in and are available in 1, 2 and 3in lengths. Celdis Ltd, 37/39 Loverock Road, Reading, Berks. RG3 1ED.

WW322 for further details

## High-voltage pulse generator

A kilovolt pulse generator providing pulse widths between 3 and 100ns with rise and fall times of 1ns has been announced by Instrument Technology. The amplitude of the pulses is continuously variable between 1kV and 9kV, and a pulse repetition rate of up to 100Hz is possible. The unit has a delay trigger circuit giving 20ns delay with 1ns jitter. Switch selection of either signal shot (push button) or repetitive shot is provided, with the repetitive application requiring a 5V positive external trigger. Instrument Technology Ltd, 67 Lower Road, Kenley, Surrey.

WW309 for further details

## Null balance voltage calibrator

A portable battery-powered d.c. voltage calibrator which incorporates a null balance indicator, is available from Time Electronics. Sensitivity is better than 2 $\mu$ V per division allowing voltages down to 1mV to be measured to better than 0.1% accuracy

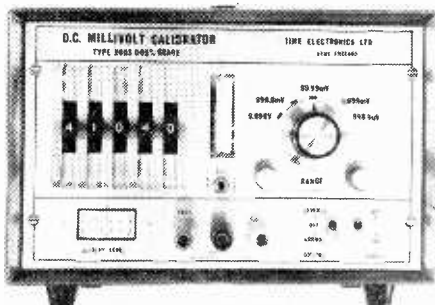

with the convenience of direct digital readout. The basic accuracy of the instrument is  $\pm 0.05\%$  of reading with the option of a  $\pm 0.02\%$  version. Voltages from 1 $\mu$ V to 10V can be measured on five ranges. The circuit uses a Muirhead standard cell as the basic reference source. A chopper stabilized amplifier provides voltage accuracy better than 25p.p.m./ $^{\circ}$ C and 100p.p.m. per annum. When used for calibration purposes the instrument can supply up to 25mA without loss of accuracy. Time Electronics Ltd, Elliott Road, Bromley, Kent BR2 9PA.

WW303 for further details

## Push-button tuner

Sydney S. Bird & Sons have introduced a new push-button tuner for car radio receivers with the special advantage of enabling manufacturers to design sets down to 42mm high while still being suitable for receivers up to 51mm high and with U.K. and Continental spindle centres, of

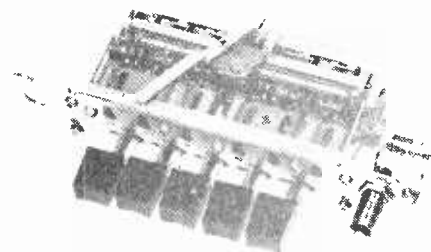

130mm and 138mm. The AW160 series tuner can be supplied with 2, 3, 4, 5 or 6 coils giving a.m. and f.m. operations, and the five buttons may be sequenced in any combination of medium-wave, long-wave, or f.m. Sydney S. Bird & Sons Ltd, Cylidon Works, Fleets Lane, Poole, Dorset.

WW319 for further details

## Microwave IMPATT diodes

New diodes from Hewlett-Packard are claimed to be the first silicon IMPATTs to achieve microwave power levels higher than 1W.



**Characteristics**

	5082-0424	5082-0425	5082-0426	
Frequency range	5.3-8	8-10	10-13.5	GHz
C.W. output power (minimum)	1.5	1.25	1.0	W
Maximum junction temp. rise at rated power	175	175	175	°C
Operating voltage (typical)	125	100	80	V
Operating current (typical)	220	210	200	mA
Efficiency (typical)	6.5	7.0	7.0	%
Thermal resistance (typical)	5.0	7.0	9.0	°C/W
Junction capacitance at breakdown (typical)	1.7	1.4	1.5	pF

The larger junction area needed is achieved by paralleling four diodes on a single chip. Hewlett-Packard Ltd, 224 Bath Road, Slough Bucks. SL1 4DS.  
**WW321 for further details**

**Low-noise professional tape**

A matt-backed a.f. tape for professional use and with the high-performance properties of untreated tape has been developed and introduced by EMI. The tape (type 816) is claimed to be superior to other matt-backed tapes in terms of both modulation noise and print through. (The advantage of matt-backed tapes is the higher 'spooling' speed and uniform wind.) A recently developed method of measuring modulation noise, which gives better agreement between noise and its subjective effect, is used in assessing the new tape. Ratio of 1-kHz maximum replay level to a.m. noise is -38.5dB, to d.c. noise is -49dB and to bias noise is -74dB (6.55mm track width, 38cm/s). The tape is available in the four standard widths and is intended for operation at 38 or 19cm/s. EMI Tape Ltd, Hayes, Middx.  
**WW301 for further details**

between transmitted and reflected pulses, which are displayed on a built-in monitor oscilloscope, the system achieves an accuracy of 0.1%, with a resolution of 1 metre over its distance measuring range of 20 to 19,999 metres. Front panel controls are provided for setting the propagation constant of the cable under test and for varying the pulse width when required. The distance to the fault or to the end of the cable is given in metres as a direct-reading 5-digit display. Euro Electronic Instruments Ltd, Shirley House, 27 Camden Road, London N.W.1.  
**WW306 for further details**

**TV camera for low light levels**

The Esicon (TX538), a sensitive pick-up tube from Thomson-CSF, uses 1in vidicon-type hardware. The principle of operation is that within an image section electrons emitted by the photocathode are accel-

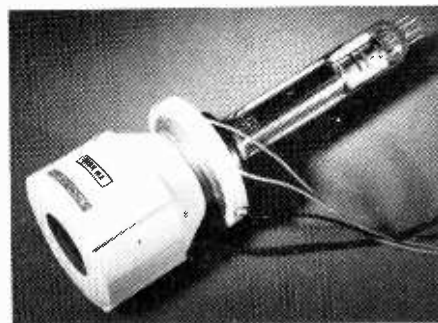

ated, focused, and then strike one side of an electron multiplier target, where they are then multiplied while penetrating the target material. On the readout side, the 'charge

pattern' is analyzed by means of a low velocity vidicon-type electron beam. The purely dielectric nature of the target permits long lasting charge accumulation: faint images can be extracted out of the photon noise and enhanced through integration. Lag is very low, allowing non-smear pictures with fast moving objects. As the Esicon photocathode is deposited on a fibre optic faceplate, an image intensifier stage can easily be coupled in front of the pick-up tube. As such the Super-Esicon (TX540) is capable of live pick-up for example in the low light level conditions of an overcast, moonless night ( $10^{-4}$  to  $10^{-5}$  lux). If an appropriate scintillator crystal is attached in front of the photocathode of the Esicon (or of the image intensifier stage) the device becomes sensitive to X, gamma or neutron radiation. Thomson-CSF Electronic Tubes Ltd, Bilton House, Uxbridge Road, Ealing, London W5 2TT.

**WW327 for further details**

**Mains input filters**

Waycom Semiconductors are marketing the Schaffner FN series of encapsulated mains input filters handling up to 15A. The series provides high attenuation of frequencies up to 300MHz, and units are available in either plastic or metal cases. Waycom Semiconductors Ltd, Wokingham Road, Bracknell, Berks.

**WW326 for further details**

**High-current silicon transistors**

Two TO3 encapsulated transistors, types 2N3771 and 2N3772, with a maximum dissipation rating of 150W and a current rating of 30A are available from Mullard. Both are n-p-n devices. Characteristics:

	2N3771	2N3772	
Max. $V_{CBO}$	50	100	V
Max. $V_{CEO}$	40	60	V
Max. $I_{CM}$	30	30	A
Max. dissipation, $P_{Tot}$	150	150	W
Max. junction temperature	200	200	°C
$h_{FE}$			
$V_{CE}=4V,$ $I_C=10A$		15 to 60	
$V_{CE}=4V,$ $I_C=15A$	15 to 60		

Mullard Ltd, Mullard House, Torrington Place, London WC1E 7HD.  
**WW310 for further details**

**Logic-card range**

A new type of logic card has been introduced by Viking Industries (UK) to accept 14- and 16-pin i.c. sockets and wire-wrap posts for discrete components in any

**Fault locator for long cables**

The Takeda TR-4902 digital cable-fault locator from Euro Electronic Instruments, gives a direct reading of fault position or cable length for submarine, underground, communications, or aerial cables. Using an electronic counter to measure the interval

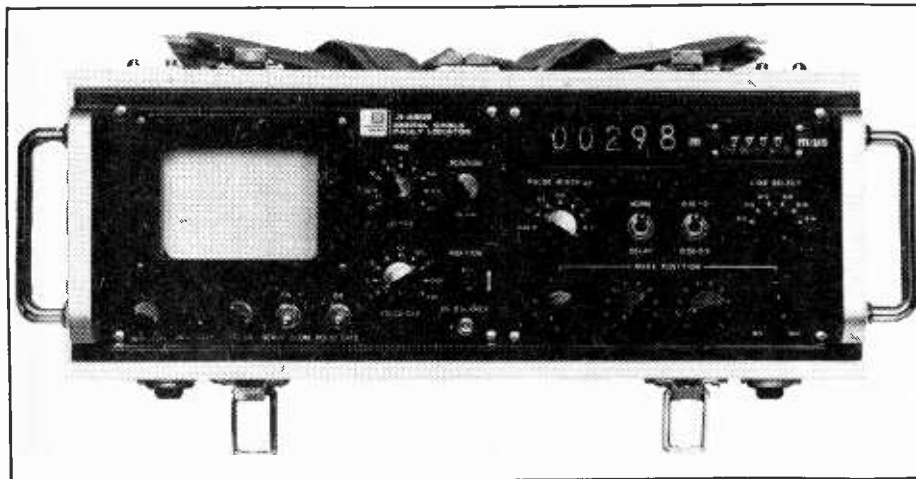

Continued on p. 199

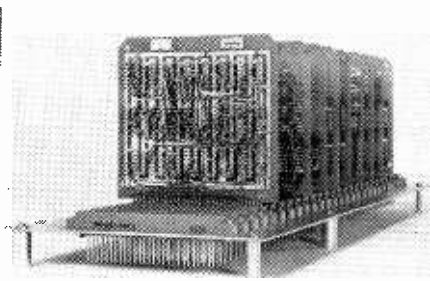

combination. Two card sizes are available ( $4.5 \times 4.5$ in and  $9.25 \times 4.5$ in) giving an almost unlimited number of configurations. Both sizes have 35-way double-sided gold-plated contacts for standard p.c. connectors. Cards with pins already inserted to customer requirements can be supplied. Viking Industries (UK) Ltd, Barton Industrial Estate, Faldo Road, Barton-le-Clay, Beds.

WW311 for further details

### Insulating washers

Insulating washers for semiconductors in TO-3, TO-66 (2 and 9pin), SO-55, DO-4, DO-5 and 'thermatap' packages are now available from Jermyn. Manufactured from I.C.I. 'Melinex' polyester film the washers

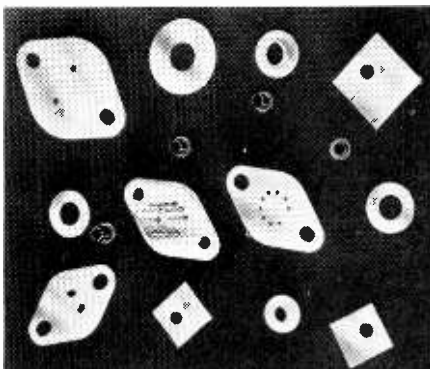

are 0.002in thick, tough, and flexible. The thermal performance is good.— for the TO-3 washer it is typically  $0.8^\circ\text{C/W}$  including the two interfaces. Jermyn Industries, Vestry Estate, Sevenoaks, Kent.

WW315 for further details

### Low cost diacs

Hutson Industries type D-30 diac, from Claude Lyons, is suitable for use as a trigger for triacs and s.c.r.s. The breakover voltage is  $32\text{V} \pm 4\text{V}$ , and breakover symmetry  $\pm 3\text{V}$ . The diode is DO-7 encapsulated. Prices start at 22p for 1-24. Claude Lyons Ltd, Hoddesdon, Herts.

WW320 for further details

### 40MHz oscilloscope

A dual-beam, 40MHz oscilloscope made by Advance Electronics has a deflection factor of  $5\text{mV/cm}$  at full bandwidth. The solid-state oscilloscope, type OS3000, has an alternate deflection factor of  $1\text{mV/cm}$

up to 10MHz. A dual timebase with calibrated delay gives a choice of timebase A only, A bright-up by B, B delayed by A, or A and B mixed, this last a feature new to oscilloscopes of the same cost. (Ranges extend from  $2\text{s/cm}$  to  $200\text{ns/cm}$ , and down to  $20\text{ns/cm}$  with  $8 \times 10$  expansion.) It is designed for easy customer repair — the timebase, power supply and e.h.t. units for instance are easily removed and extension leads allow oscilloscope operation with the units removed. A useful feature is

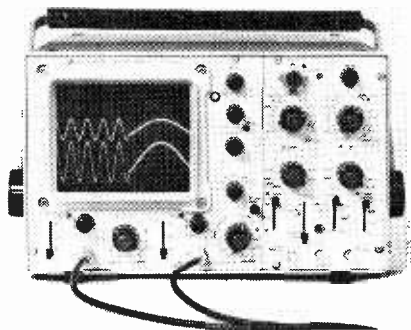

a Y-amplifier output which permits cascade operation of the two Y-amplifiers to give a deflection factor of  $200\mu\text{V/cm}$ . The Y-amplifier output can also of course be used to feed the X-input. Rise time of the Y amplifiers is less than 9ns. Overshoot is constant with varying attenuation. Display area is  $10 \times 8\text{cm}$ . Price £360. Advance Electronics Ltd, Raynham Road, Bishop's Stortford, Herts.

WW329 for further details

### D.C. millivoltmeter

A wide-range millivoltmeter from Noronix, type NVM 1, has 11 voltage ranges from 100V full-scale down to a maximum sensitivity of  $1\text{mV}$  full-scale, giving  $10\mu\text{V}$  resolution. Input resistance is  $1\text{M}\Omega/\text{V}$ . For transducer applications a full-scale reading may be obtained with a signal anywhere in the range  $300\mu\text{V}$  to 100V. The case is nylon-coated steel with recessed plastic-fronted meter. The meter will with-



stand high electrical overloads. The battery power supply is stabilized, and the 'sampling-chopper' d.c. amplifier gives good rejection of interfering a.c. signals. Price £36. Noronix Ltd, Love Lane, Woolwich, London SE18 6HL.

WW328 for further details

### Electrolytic capacitors

Single or multiple section electrolytic capacitors, type 35D from Sprague, are available in the range 6.3-450V. The largest capacitance available for standard units is  $2 \times 23,500\mu\text{F}$  at 6.3V d.c. The capacitors can be operated over a temperature range of  $-40$  to  $+85^\circ\text{C}$ , and can tolerate high ripple current. A pressure-type safety vent is standard. Sprague Electric (UK) Ltd, 159 High Street, Yiewsley, West Drayton, Middx.

WW323 for further details

### Miniature light-emitters

Light-emitting diodes types 183CQY and 185CQY from Mullard, are miniature gallium arsenide phosphide devices that emit bright red light through a wide angle. The 183CQY is intended to replace conventional indicator lamps in systems that use solidstate circuits. It operates with a power supply of 2V at 20mA to produce a radiation with an intensity of  $170\text{cd/m}^2$ , and has an impedance of about  $100\Omega$ . The 185CQY can display the numbers 0 to 9 and the decimal point. It operates with a power supply of 2V at 5mA and emits radiation with an intensity of  $684\text{cd/m}^2$ . The numbers, which measure only  $2 \times 3\text{mm}$ , are formed as a standard 7-segment display. Mullard Ltd, Mullard House, Torrington Place, London WC1E 7HD.

WW314 for further details

### High-voltage pulse transformer

A 30kV pulse transformer model 355-30, manufactured by Hartley Measurements, is designed to trigger spark gaps, flash tubes, etc. It can be operated by a low-cost thyristor circuit or, for high-speed applications by a thyratron. It measures  $96 \times 25 \times 25\text{mm}$  approx. and is suitable for printed-circuit board mounting. Output is 30kV for a 300V input pulse; rise time less than  $1\mu\text{s}$ . Hartley Measurements Ltd, Kent House, High Street, Hartley Wintney, Hants.

WW307 for further details

### High-resolution digital voltmeter

Model 701 digital voltmeter from Fenlow has a resolution of 1 part in 20,000, sensitivity of  $10\mu\text{V}$ , input resistance of  $20,000\text{M}\Omega$  and accuracy of 0.01%. A new



conversion technique employed avoids switching at low levels. Series mode rejection is 80dB. The instrument measures  $210 \times 75 \times 140$ mm approx. Price £198. Fenlow Electronics Ltd, Whittet's Eyot, Jessamy Road, Weybridge, Surrey. WW313 for further details

### Low-power audio amplifier i.c.

An integrated circuit audio amplifier, type TBA915, from Mullard, is intended for use in portable receivers and miniature transmitter-receivers where small battery size is important. Under typical operating conditions, the circuit normally takes a current of 2.5mA when quiescent, but a squelch facility can reduce this to  $400\mu\text{A}$ . Output is up to 500mW. The high-frequency response of the TBA915 can be adjusted by means of capacitance in the feedback path. An input of 10mV will produce full output; signal-to-noise ratio at this power level is 75dB. Encapsulation is TO-74. Mullard Ltd., Mullard House, Torrington Place, London WC1E 7HD. WW330 for further details

### Quadraphonic pan pot

Intended for studio use, the quadraphonic panoramic potentiometer made by Sigma Products claims to be cheaper than its competitors. Movement of a single control knob gives proportional control of four potentiometers. The potentiometers are high-resolution, low-noise wirewound types

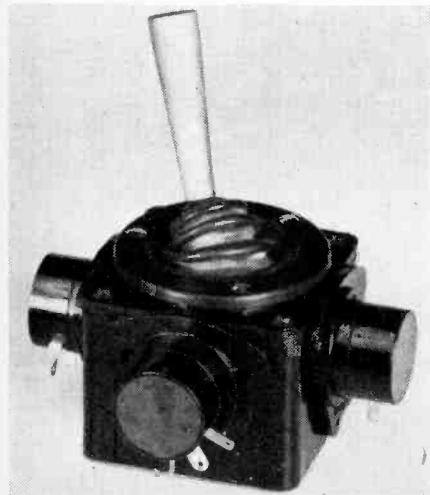

with a value of  $3.9\text{k}\Omega$  and a linear law (The law can be modified with external resistors.) Unit price is £15.75. Sigma Products Ltd, 72 St. Andrews Road, Northampton. WW302 for further details

### Bistable relay

Magnetic Devices have announced a bistable relay with coils for d.c. working. With each successive operation the solenoid actuates a cam into either high or low positions. Thus the contacts are operated every alternate time the relay is energized. Contact arrangements are built

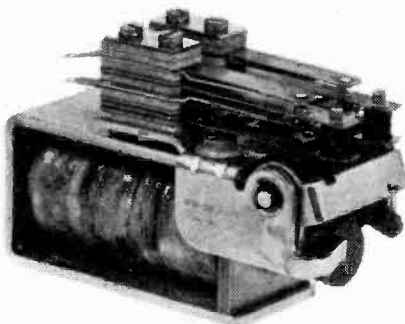

up as required from single pole to a maximum of four poles. Provision is made for alternative contacts which can be operated direct from the solenoid if required. Coils can be wound for up to 230V d.c. Magnetic Devices Ltd, Exning Road, Newmarket, Suffolk. WW312 for further details

### Solid-state microwave signal source

Microwave signal source, type 6070 from Marconi Instruments covers the frequencies 400 to 1200MHz in a single range. It has mechanical/digital readout. The instrument contains an i.c. power supply, square-wave generator and modulator drive circuit assembled on to a single printed-circuit board fitted with an edge connector. Frequency stability is typically 0.001%. A transistor cavity-controlled oscillator gives a minimum power output over the whole frequency band in excess of 50mW with a typical maximum power of 250mW. The r.f. output line incorporates a p-i-n

diode modulator and low-pass filter. External amplitude and modulation can be applied through a front panel B.N.C. socket. Optional accessories include a levelling amplifier and a wideband detector. Marconi Instruments Ltd, St. Albans, Herts.

WW324 for further details

### Encapsulated bridge rectifiers

Two silicon single-phase bridge rectifier assemblies from Westinghouse, types SxPF3 and SxPF4, have voltage ratings of 80-1000V<sub>RRM</sub>. Current ratings are 9A (225A overload) and 13A (300A overload) for the SxPF3 and SxPF4 respectively. Prices are £108 per 100 for the S1PF3 (100V) and £127 per 100 for S1PF4 (100V). Westinghouse Brake and Signal Co. Ltd, 82 York Way, King's Cross, London N1 9AJ.

WW325 for further details

### Pulse generator

Model TT100 the first of a new range of pulse generators from K.S.M. Electronics provides a p.r.f. of 1Hz-7MHz, delay of 50ns-1s, pulse width of 50ns-1s, and a positive and negative pulse obtained from separate sockets, each pulse being variable from zero to 10V into  $50\Omega$ . The instrument measures  $89 \times 140 \times 324$ mm. K.S.M. Electronics Ltd, Bradmore Works, Brookmans Park, Hatfield, Herts. WW317 for further details

### Versatile multimeter

The Normatest 2000, made by Norma of Vienna and available in the U.K. from Croydon Precision Instrument Co, has 41 ranges with facilities for the measurement of a.c. and d.c. voltage and current, resistance, temperature and gain. It has an internal resistance of  $20,000\Omega/\text{V}$  d.c. and  $4,000\Omega/\text{V}$  a.c. The moving-coil system is

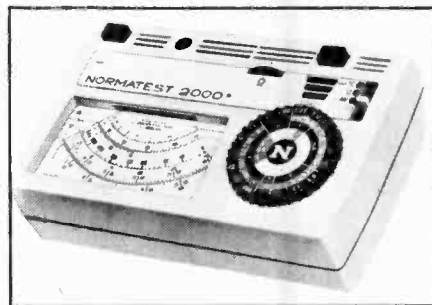

a taut-band suspension with a short-term overload capacity of 1,000 to 1 and a built-in fuse to ensure maximum overload protection. The instrument is contained in a plastic case and accessories such as temperature feelers, range multipliers and clip-on transformers are available. Price complete with carrying case and test leads is £17.50. Croydon Precision Instrument Co., Hampton Road, Croydon CR9 2RU. WW304 for further details

# Literature Received

For further information on any item include the appropriate WW number on the reader reply card

## ACTIVE DEVICES

The 1972 catalogue from Chromasonic Electronics, 56 Fortis Green Road, London N10 3HN, gives prices and specifications of all their components (active and passive) .....WW401

A data sheet is available on the MM1101, 11011, MM1101A1 and 1101A2 256-bit fully decoded static random access memory i.c.s and an application note on the use of MM5260. National Semiconductor (U.K.) Ltd, Larkfield Industrial Estate, Greenock, Scotland .....WW402

Specifications of a 30A (Io) power thyristor 31RCS. are given in a data sheet from International Rectifier, Hurst Green, Oxted, Surrey .....WW403

James Millen Manufacturing Co. Inc, 150 Exchange Street, Malden, Massachusetts 02148, have sent us a booklet containing details of their components, grid dip meters, amateur radio equipment, module oscilloscopes, magnetic shields and delay lines .....WW443

We have a booklet describing Signetics range of linear and operational amplifiers, comparators, phase locked loops and m.o.s. products. Quarndon Electronics Ltd, Slack Lane, Derby .....WW444

## PASSIVE COMPONENTS

Celdis Ltd, Loverock Road, Reading — distributor for London Electrical Manufacturing Co. Ltd — have produced a wall chart for comparison of dielectrics .....WW404

A brochure 'Aerials and Accessories' gives technical details of equipment from J. Beam Aerials Ltd, Rothersthorpe Crescent, Northampton .....WW405

A catalogue contains details of the range of quartz crystal filters manufactured by Salford Electrical Instruments Ltd. Peel Works. Eccles. Manchester M30 0HL .....WW406

Two publications about Cambion Electronic Products Ltd, Cambion Works, Castleton, Nr. Sheffield, S30 2WR are:

Multilanguage Catalogue 102A on terminals, r.f. chokes and connectors .....WW407  
'Product News' .....WW408

A data sheet is available covering all switches from Birch-Steele Ltd, Ponswood Industrial Estate, Windmill Road, Hastings, Sussex .....WW411

## APPLICATIONS

Technical Publication No. 4 from Waycom Semiconductors Ltd, Wokingham Road, Bracknell, Berks, is called 'Mains Filters for Equipment using Digital Integrated Circuits' .....WW412

'Detecting Sources of Vibration and Noise using H.P. Fourier Analyzers' is note 140-1 from Hewlett-Packard Ltd, 224 Bath Road, Slough, Bucks .....WW413

## EQUIPMENT

A leaflet is available on modular 35MHz oscilloscope 3100. Cossor Electronics Ltd, The Pinnacles, Elizabeth Way, Harlow, Essex .....WW414

'Abridged catalogue of process instrumentations' is a booklet giving general information on products from Honeywell Ltd, Charles Square, Bracknell, Berkshire .....WW415

We have received two publications from Foxboro-Yoxall Ltd, Redhill, Surrey.  
'Process Control Information: with explanatory notes' .....WW416  
Details of the extended process computer range, FOX2 .....WW417

Data sheets on recent Rhode & Schwarz instruments are available. Aveley Electric Ltd, Arisdale Avenue, South Ockendon, Essex RM15 5SR .....WW418

Aero Electronics (AEL) Ltd, Gatwick House, Horley, Surrey, have several data sheets describing a range of radio communications equipment, which includes the h.f. s.s.b. transceiver AEL 3015A .....WW419

Catalogue No. 8172 ('Electronics Catalogue 1972') from Eagle International, Precision Centre, Heather Park Drive, Wembley, Middx, describes their range of audio equipment, electronic components and accessories .....WW420

Digital measuring instruments from Farnell Instruments Ltd, Sandbeck Way, Wetherby, Yorkshire LS22 4DH, are described in Publication T1 .....WW421

We have a leaflet describing a range of audible circuit and voltage testers produced by Coventry Controls Ltd, Godiva House, 49 Allesley Old Road, Coventry CV5 8BU .....WW422

Specification sheets of the range of Audix products are contained in a booklet. Audio Sound Systems and Electronics, Stansted, Essex .....WW423

A booklet on sound control consoles gives general facilities and performance specifications. Cadac (London) Ltd, Stansted, Essex .....WW424

Data sheets on the products of At Yu Electronics cover oscilloscopes, phase meters and power supplies. B. Hepworth & Co. Ltd, P.O. Box 10, Bank Buildings, Kidderminster, Worcs. ....WW425

Tally Corporation, 8301 South 180th Street, Kent, Washington 98031, have sent us a leaflet describing their on- and off-line print station .....WW426

The Soundcraftsmen RP10-12 professional recording/playback equalizer is described in a news sheet. The unit is for tape, disc and p.a. use. Soundcraftsmen: 1310 E. Wakenham Avenue, Santa Ana, California 92705 .....WW427

We have a leaflet describing the Series IT7000 ignition tachometer. The meter is for use with capacitor electronic ignition systems. Dynalco Corporation, 4107 N.E. 6th Avenue, Ft. Lauderdale, Florida 33308 .....WW428

'LI Newsletter' contains product news from Lyons Instruments Ltd, Hoddesdon, Herts .....WW429

Computer Automation Incorporated Ltd, 95a High Street, Rickmansworth, Herts, have sent us a leaflet on CAPABLE — a minicomputer-based logic circuit testing system .....WW430

A news sheet describes model 3720A spectrum display, which provides frequency and time analysis of electrical signals when combined with digital correlator 3721A. Hewlett-Packard Ltd, 224 Bath Road, Slough, Bucks, SL1 4DS .....WW431

A series of electronic units from Ortofon for disc recording studios includes a cutting head amplifier (GO 701), which can transfer a sine wave power of 500W. The amplifier and its power supply (GE 701) are described in a leaflet. Ortofon A/S, 5 Trommesalen, DK-1614 Copenhagen V, Denmark .....WW445

## GENERAL INFORMATION

'General Conditions of Contract 1972: Parts I & II' is a revised version applicable from 1st March 1972. Crown Agents (for overseas governments and administrations), CS Department, 4 Millbank, London SW1P 3JD .....WW433

Portescap (U.K.) Ltd, 204 Elgar Road, Reading, RG2 0DD, have produced the ESCAP 26P series of high-performance d.c. micromotors, which are described in a leaflet .....WW435

We have received details of the new electronic maintenance and calibration service for test and measuring equipment offered by EMI Service, The Installation and Maintenance Division of EMI Electronics Ltd, Blyth Road, Hayes, Middx. ....WW436

Five publications from the British Standards Institution, 2 Park Street, London W1A 2BS are:

BS9027: 1972 'Rules for the preparation of detail specifications for forward travelling — wave power tubes of assessed quality' .....Price £1  
BS9610:1972 'Quartz crystal units of assessed quality for oscillator applications: Generic data and methods of test' .....Price £2  
BS9000 'General requirements for electronic components of assessed quality Part 2:1972 Data on generic and detail specifications' .....Price £1.10  
BS800 Part 1:1972 'Radio interference limits and measurements. Equipment embodying small motors' .....Price 90p  
BS800 Part 3:1972 'Radio interference limits and measurements. Semiconductor control devices' .....Price 70p

We have received two leaflets from the British Broadcasting Corporation, Engineering Information Department, Broadcasting House, London W1A 1AA.

'How to receive B.B.C. T.V. 625 lines and colour'  
'V.H.F. radio transmitting stations'

Studio 99 Video Ltd, 81 Fairfax Road, Swiss Cottage, London N.W.6, have sent us a new list of video tape prices and 'Fact Sheet No. 2' containing information on new products and using microphones and TV cameras in poor light .....WW439

'Multirange' units for use with Interscale educational instruments are described in a leaflet. White Electrical Instrument Co. Ltd, Spring Lane North, Malvern Link, Worcs, WR14 1BL .....WW440

'Special Metals' is a leaflet (German or English versions), which summarizes available metals and applications. There is also a sheet on rhodium and iridium crucibles for the production of monocrystals. Degussa Public Relations Department, D6000 Frankfurt am Main 1, Postfach 3993 .....WW441

Butterworths, 88 Kingsway, London WC2B 6AB, have produced two leaflets describing books available on radio and television .....WW442

Information on educational literature from Mullard Ltd, New Road, Mitcham, Surrey CR4 4XY is contained in the 'Educational Service Bulletin' .....WW409

Details and prices of new films (On to Mach-2, Learning Metric, Intrium, Insight, Momentum of Electrons, Looking at Ourselves) are given in a leaflet from the Central Film Library, Government Building, Bromyard Avenue, Acton, London W3 7JB .....WW410

# Real and Imaginary

by "Vector"

## 'It will not last the night —'

Burning the candle at both ends, although an expressive metaphor, is something I find difficult to do literally; as a consequence this is being written with the aid of the conventional single-ended guttering flame — at the time of putting pen to paper we are still in the power-cut era.

During the past few years we have had more than a basinful of national strikes; the postmen, the power-station engineers and now the miners have all made their respective points. The two last-mentioned have given those of us who live in all-electric homes, or rely upon electrically-operated fuel pumps, a sharp taste of what it must have been like to winter in the Flintstone era. Come to think about it though, the Flintstones had the edge over us with a crackling wood fire at the cave mouth.

But our shivering won't have been in vain if it has made us reflect upon where our boasted technologies have got us. This is the age of the specialist, in which the individual is quite helpless to provide at first hand the fundamentals of life for his family. More diabolical still, he can't even provide them at second hand unless he has the tacit approval of a handful of key men. In short, neither our own electronics industry nor any other is the discrete watertight compartment which in less troubled times we imagine it to be. We are inextricably linked one to the other, with main arteries feeding us with raw materials. A blockage of one of those sources and the country suffers a thrombosis.

Don't misunderstand me; I'm not knocking the miners. My own personal views about them (for what the thoughts are worth) are governed by the amount of money I would want for risking death by crushing, explosion, fire, gas or silicosis. No, it's the insane principle whereby 56 million people can be hi-jacked by a handful — however just their cause might be — which is the point at issue.

The basic trouble lies in that incredible computer which is the human brain; it's so fearfully adept at devising new technologies but so woefully inept at providing the wisdom with which to apply them properly. While lip-service is paid to easing the lot of the community the prime mover in technological innovation is profit; as a consequence we are exhausting world supplies of raw materials at a lunatic rate, destroying the balance of nature and

spreading pollution over the earth and the waters that cover the face of the earth. The last man on this planet will die alongside a huge pile of gold and diamonds and empty food and water pots.

When I first read Samuel Butler's 'Erewhon', well, frankly, I thought poor old Samuel wasn't in full possession of his marbles. You know the bit I'm referring to — where his hero finds that the Erewhonians had virtually no machinery in their country. At some stage in their history they had realised where the cult of technology was taking them and they had called a halt, relegating the machines to museums where they provided an admonitory lesson to the young. At the time of first reading I thought this concept incredibly stupid; only much later did I realise that the stupidity lay in me.

## An old timer's lament

You'll have seen in the March issue (page 113) that broadcasting in this country celebrates its fiftieth anniversary this year. The first station was 2MT, Writtle, and the second, 2LO, London.

The following lines were discovered on the body of an old-time radio engineer who died from an overdose of pop music: —

'I remember, I remember . . .'  
(With apologies to Thomas Hood)

I remember, I remember,  
The, callsign 2MT  
And 'Wr-r-r-rittle calling!' through the night  
And P. P. Eckersley.  
That half an hour just once a week  
Passed all too soon away  
So we demanded then to have  
A half an hour each day.

I remember, I remember,  
The callsign 2LO  
One hour per day we now received  
We moaned 'That ration's low!' —  
Today our punishment fits our crime  
By greed we are undone —  
We're lumbered now by day and night  
With squawking Radio One!

Mention of P. P. Eckersley, who was the first chief engineer of the B.B.C., reminds me that if you're interested in the beginning of things, try and get hold of a copy of his book 'The Power behind the Microphone' published in 1941 (Jonathan Cape) which gives an eminently readable

account of the start of broadcasting in this country. Writing of 2MT Writtle he tells how (after dining at the 'local') he began that irreverent approach to the microphone which was to endear him to his audience. He continues:—

"We signed off with a theme song. I sang it in a high tenor voice to the tune of Tosti's 'Goodbye'"

Dearest, the concert's ended, sad wails the heterodyne,

You must soon switch off your valves, I must soon switch off mine,

Write back and say you heard me, your 'hook-up' and where and how,

Quick! for the engine's failing; goodbye you old low-brow!"

His account in his book of how he applied for his first job is something which every young reader of *W.W.*, keen to make electronics a career, would do well to remember. Eckersley says:—

"My simple dream on leaving Bedales [school] in 1911 was to figure as a leading man of science, a great wireless inventor. . . . It is a thousand pities that everyone, keen as I was, . . . cannot have the advice given me by the genial Mr. Andrew Gray, so many years Chief Engineer of Marconi's Wireless Telegraph Company. When Mr. Gray interviewed me he asked questions about wireless . . . to all of which he got intelligent and correct answers. He then switched to questions on electrical engineering. . . . It soon became clear that I knew little or nothing about electrical engineering. Mr. Gray delivered a little lecture, the gist of which was 'Wireless is only a branch of electrical engineering and electrical engineering is founded upon the principles of electricity and magnetism. First learn about these so that you will readily understand electrical engineering and then take up wireless, when you can rise, if you have ability, to the top of the profession. Otherwise you will be bound to stick somewhere short.'"

\*Actually I think the tune was 'Parted'.

## Snap, crackle and pop

Most readers have heard of shot noise, flicker noise, current (or  $i/f$ ) noise and those noises which carry the familiar names of Johnson and Barkhausen, but who has heard of popcorn noise? Not many, I dare say. Nevertheless I came across this description, somewhat unexpectedly, in a Japanese technical journal. It turns out there is no distinguished Japanese researcher called Popcorn, nor is popcorn noise one of the unfortunate side effects of making transistors out of maize, but just a new name for what has previously been called burst or pulse noise — because it occurs as peaks of energy (typically several milliseconds apart) of much greater amplitude than the general noise waveform. I understand that one of the first people to study this type of noise, actually in 1956 in point contact germanium diodes, was Rex G. Pay for his M.Sc. thesis at Birmingham University.